

PERI Rental Criteria

Industrial Scaffolding



Contact

PERI GmbH
Formwork Scaffolding
Engineering
 P.O. Box 1264
 89264 Weissenhorn, Germany
 Phone +49 (0) 7309.950-0
 Fax +49 (0) 7309.951-0
 rental-criteria@peri.de

Content	Page
Consoles	2
Guard Rail	6
Toeboard UPY	12
Toeboard Wood UPF	14
Hatch Bottom Sheeting	16
Connection parts	19
Trolley UFS 20	24
Additional Elements	26
Glossary	29

Changes made	Date Initial	Page
New version	06/2017 fw	

PERI Rental Criteria

Industrial Scaffolding



Console UCM | Support UC

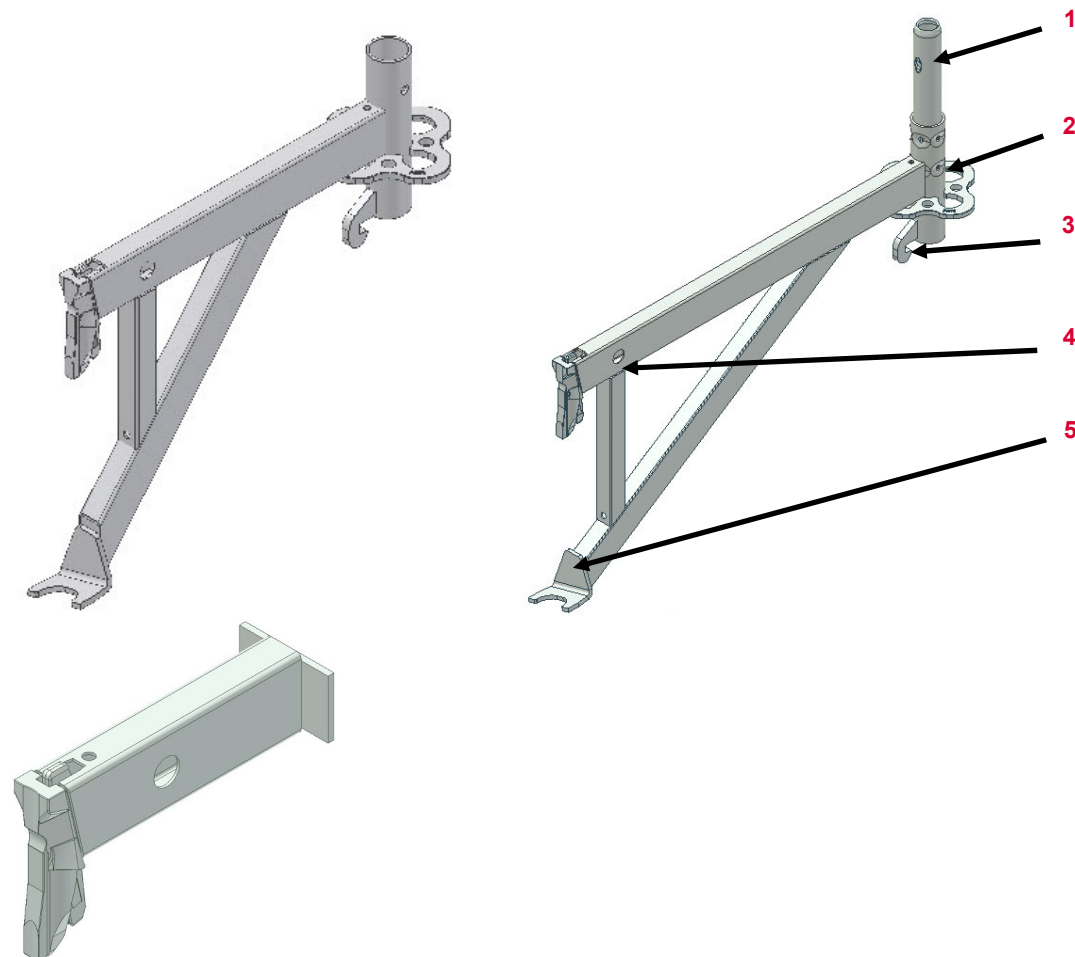

Nr.	Description	Article number
1	Spigot	
2	Rosett	
3	Bearing Protection	
4	Wedge UCM	
5	Plate UCM	





















Valid for

Console UCM 50-2	110483
Console UCM 75-2	111128
Console UCM 50 with Spigot	112676
Console UCM 75 with Spigot	112678
Console UCM 50 with Half-Rosett	112690
Console UCM 75 with Half-Rosett	112693
Support UC 25	115959
Support UC 33	130390
Support UC 37,5	115962

PERI Rental Criteria

Industrial Scaffolding













Console UCM	Description	Instruction	Billing condition	Type
	33.40.01 Bearing protection bent	<ul style="list-style-type: none"> ■ If possible  	 088244 	
	<ul style="list-style-type: none"> ■ Or if no longer possible 		 	
	<ul style="list-style-type: none"> ■ Or cracks in welding 		 	
	33.40.02 Plate UCM bent	<ul style="list-style-type: none"> ■ If possible (connection possible)  	 088244 	
	<ul style="list-style-type: none"> ■ Or if no longer possible 		 	
	<ul style="list-style-type: none"> ■ Or cracks in welding 		 	

PERI Rental Criteria

Industrial Scaffolding



Console UCM	Description	Instruction	Billing condition	Type
	<p>33.40.03 Rosett Half-rosett bent</p> <ul style="list-style-type: none"> ■ ≤ 20 mm ■ Or > 20 mm 	<ul style="list-style-type: none">   	<ul style="list-style-type: none">  088244  	<ul style="list-style-type: none">  
	<p>33.40.04 Wedge opening torn out wedge missing</p>			

PERI Rental Criteria

Industrial Scaffolding



















Console UCM	Description	Instruction	Billing condition	Type
	33.40.05 Dent in Hook	<ul style="list-style-type: none"> ■ If possible 	088244	
	<ul style="list-style-type: none"> ■ Or if not possible 			
	<ul style="list-style-type: none"> ■ Or crack in material 			
	33.40.06 Hole dented	<ul style="list-style-type: none"> ■ If original geometry of hole unchanged 	088244	
	<ul style="list-style-type: none"> ■ Or if changed 			
	<ul style="list-style-type: none"> ■ Or cracks in material 			

PERI Rental Criteria

Industrial Scaffolding











End Guardrail UPA (130476; 130583)	Description	Instruction	Billing condition	Type
	<p>33.40.07 Spigot bent</p> <ul style="list-style-type: none"> ■ If possible (Spigot insertion possible) ■ Or if no longer possible ■ Or cracks in material or welding 	<ul style="list-style-type: none">    	<ul style="list-style-type: none">  088244   	<ul style="list-style-type: none">   
	<p>33.40.08 Fork bent</p> <ul style="list-style-type: none"> ■ If possible (Connection of guardrail possible afterwards) ■ Or if not possible 	<ul style="list-style-type: none">   	<ul style="list-style-type: none">  088244  	<ul style="list-style-type: none">  

PERI Rental Criteria

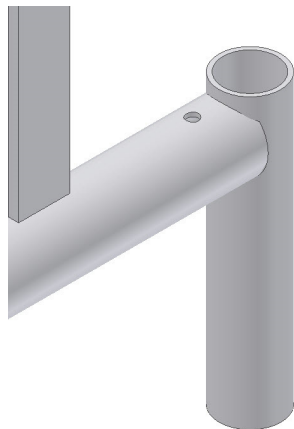
Industrial Scaffolding



Guardrail (110478; 116691)	Description	Instruction	Billing condition	Type
	<p>33.40.09 Bearing bent unusable</p>	<p> 110565 (Bearing)</p>		
	<p>33.40.10 Tube bent</p> <ul style="list-style-type: none"> ■ Guardrail can't be inserted 	<p> </p>		

PERI Rental Criteria

Industrial Scaffolding



Swing Ledger UPK (110072; 116695; 117192)	Description	Instruction	Billing condition	Type
---	-------------	-------------	-------------------	------



33.40.11 Local dent in profile

- Edges not affected



33.40.12 Wedge-opening torn out | wedge missing



PERI Rental Criteria

Industrial Scaffolding



Swing Ledger UPK (110072; 116695; 117192)	Description	Instruction	Billing condition	Type
---	-------------	-------------	-------------------	------



33.40.13 Profile bent at edge

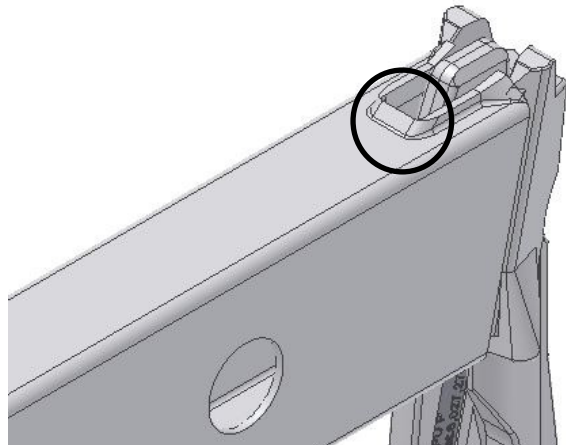

33.40.14 Dent at hook

- If possible
- Or if no longer possible
- Or crack in material



088244



PERI Rental Criteria

Industrial Scaffolding



Swing Ledger UPK (110072; 116695; 117192)	Description	Instruction	Billing condition	Type
---	-------------	-------------	-------------------	------



33.40.15 Hole dented

- If original geometry of hole unchanged
- Or if changed
- Or cracks in material



088244

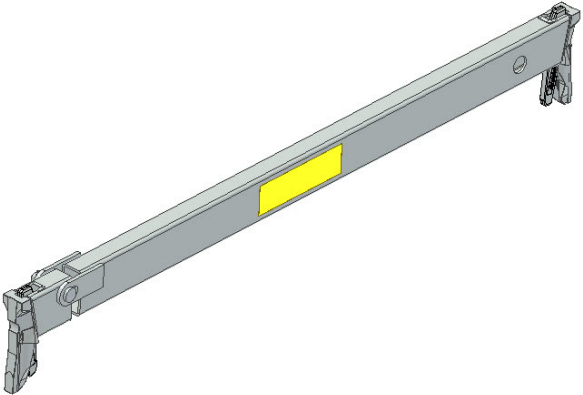

33.40.16 Bent Ledger











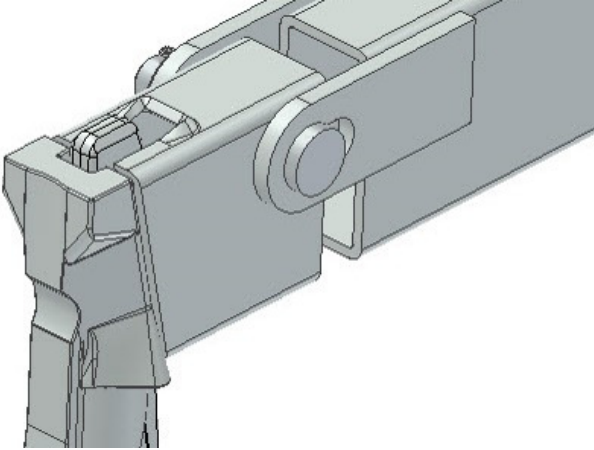

- Visible Deformation

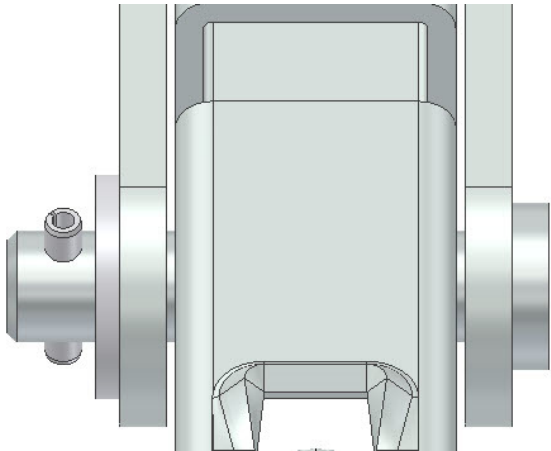

PERI Rental Criteria

Industrial Scaffolding



Swing Ledger UPK (110072; 116695; 117192)	Description	Instruction	Billing condition	Type
	33.40.17 Wedge connector	<ul style="list-style-type: none"> <li data-bbox="1305 555 1787 627">  110075 (Wedge connector) 		
	<ul style="list-style-type: none"> <li data-bbox="869 707 1294 735"> ■ Damaged due to violence 	<ul style="list-style-type: none"> <li data-bbox="1305 707 1787 778">  110075 (Wedge Connector) 		
	33.40.18 Bolt Dowel pin washer missing	<ul style="list-style-type: none"> <li data-bbox="1305 991 1787 1086">  117451 (Bolt) <li data-bbox="1305 1023 1787 1062">  722930 (Dowel pin) <li data-bbox="1305 1054 1787 1086">  780702 (Washer) 		

PERI Rental Criteria

Industrial Scaffolding



Toeboard Steel UPY	Nr.	Description	Article number
--------------------	-----	-------------	----------------



1 Edges

















2 Toeboard

Valid for	Item number
Toeboard Steel UPY 50	110213
Toeboard Steel UPY 67	129947
Toeboard Steel UPY 72	110526
Toeboard Steel UPY 75	110514
Toeboard Steel UPY 100	110073
Toeboard Steel UPY 104	110076
Toeboard Steel UPY 150	110160
Toeboard Steel UPY 200	110176
Toeboard Steel UPY 250	110208
Toeboard Steel UPY 300	110211
Toeboard Steel UPY 50 Galv.	117495
Toeboard Steel UPY 72 Galv.	117938
Toeboard Steel UPY 75 Galv.	117518
Toeboard Steel UPY 100 Galv.	117981
Toeboard Steel UPY 104 Galv.	123597
Toeboard Steel UPY 150 Galv.	123694
Toeboard Steel UPY 200 Galv.	123696
Toeboard Steel UPY 250 Galv.	123698
Toeboard Steel UPY 300 Galv.	123700

PERI Rental Criteria

Industrial Scaffolding



Toeboard Steel	Description	Instruction	Billing condition	Type
	33.40.19 Edges bent	<ul style="list-style-type: none"> ■ If possible 	 088244	
	<ul style="list-style-type: none"> ■ If no longer possible 			
	33.40.20 Toeboard bent over whole length	<ul style="list-style-type: none"> ■ If still possible and Bent $\leq L/100$ 	 088244	
	<ul style="list-style-type: none"> ■ If no longer possible ■ Or bent $> L/100$ 			
	33.40.21 Dents in toeboard		 088244	

PERI Rental Criteria

Industrial Scaffolding



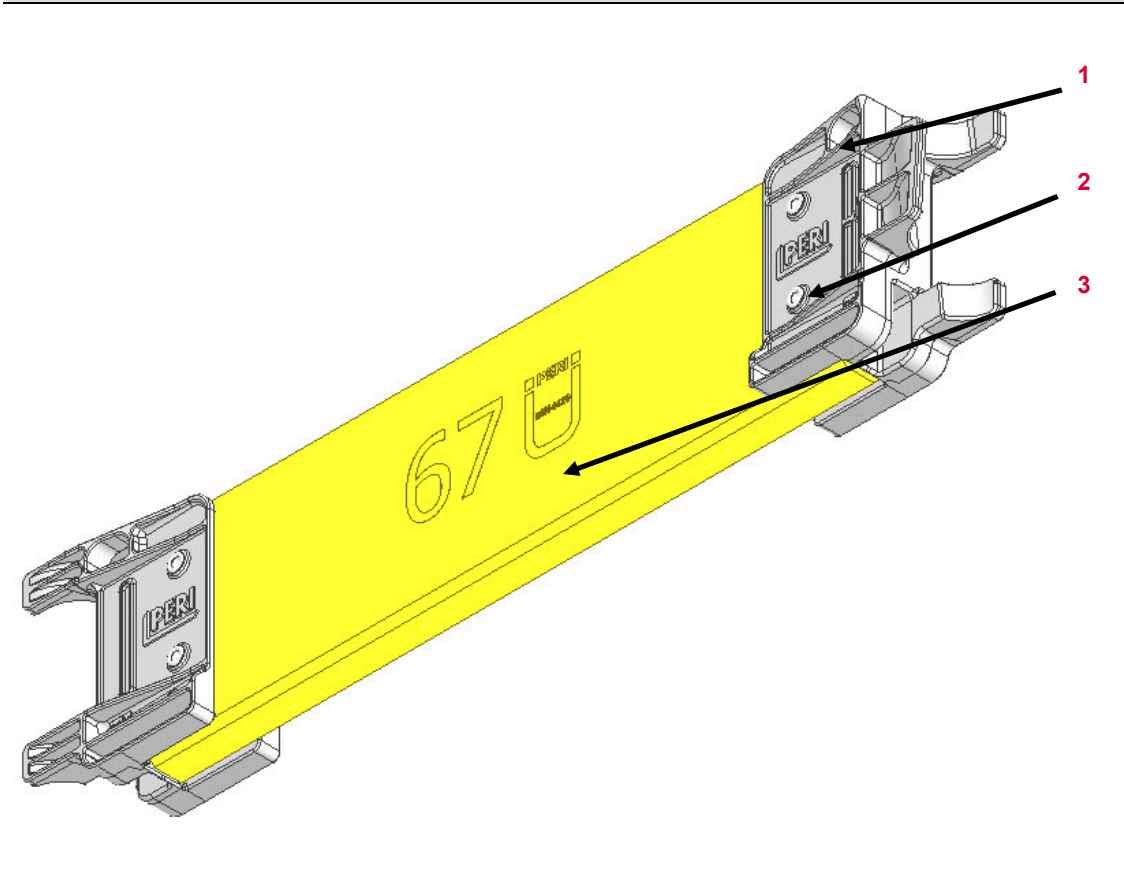







Toeboard Wood UPF	Nr.	Description	Article number
	1	Toeboard hinge	
	2	Rivet	
	3	Toeboard	
	Valid for		Item number
	Toeboard Wood UPF 50		129490
	Toeboard Wood UPF 67		129492
	Toeboard Wood UPF 75		129494
	Toeboard Wood UPF 100		129496
	Toeboard Wood UPF 150		129498
	Toeboard Wood UPF 200		129500
	Toeboard Wood UPF 250		129502
	Toeboard Wood UPF 300		129504

PERI Rental Criteria

Industrial Scaffolding



Toeboard Wood UPF	Description	Instruction	Billing condition	Type
	<p>33.40.22 Prongs broken off</p>			
	<p>33.40.23 Toeboard</p> <ul style="list-style-type: none"> ■ Broken due to violence 			

PERI Rental Criteria

Industrial Scaffolding



Hatch UAF Bottom Sheeting UDP	Nr.	Description	Article number
---------------------------------	-----	-------------	----------------

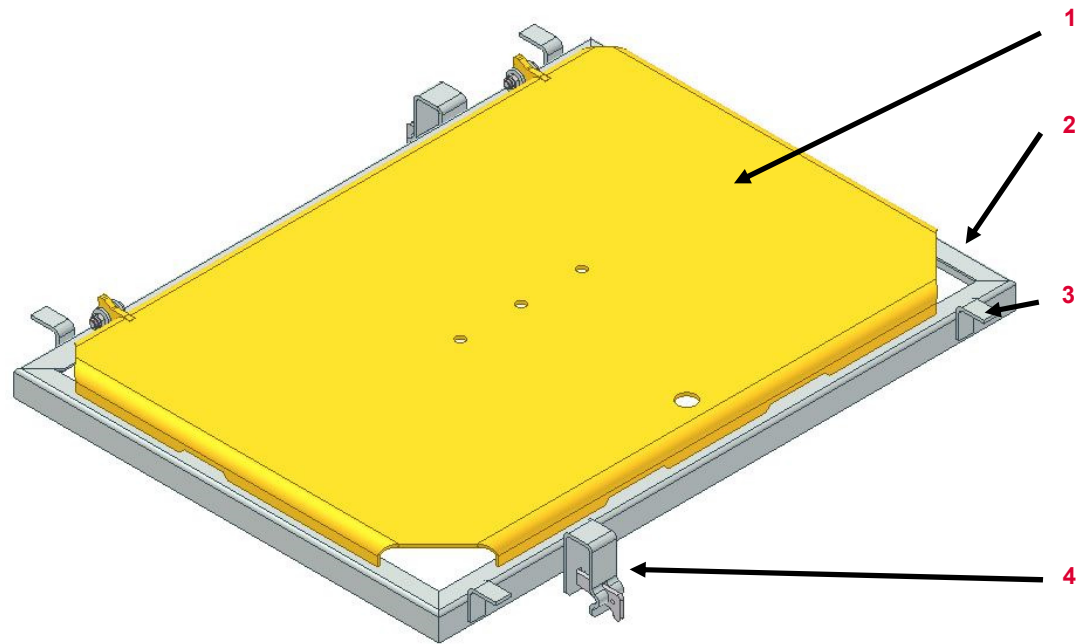

1	Cover	
2	Frame	
3	Hook	
4	Bracket	

Valid for	Item number
Hatch UAF 50x75	09783
Hatch UAF 75x100	109755
Bottom sheeting UDP 75	111101
Bottom sheeting UDP 100	112809
Corner Sheeting UDC 75	114148
Corner Sheeting UDC 100	113358

PERI Rental Criteria

Industrial Scaffolding



Hatch UAF Bottom Sheeting UDP	Description	Instruction	Billing condition	Type
---------------------------------	-------------	-------------	-------------------	------



33.40.24 Hook massively deformed, torn out



33.40.25 Bracket cracked

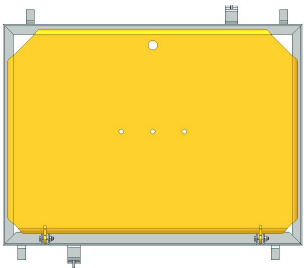

33.40.26 Cover damaged | unusable













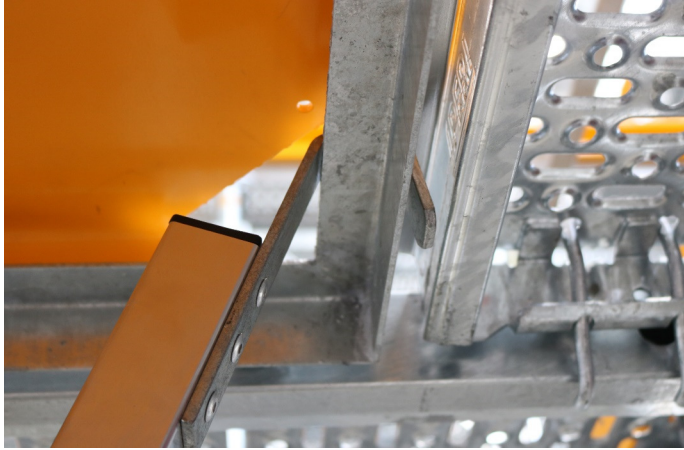





110214 (75x100)
110275 (50x75)



PERI Rental Criteria

Industrial Scaffolding



Ladder UAF 200 (109879)	Description	Instruction	Billing condition	Type
	33.40.27 Hook bent	<ul style="list-style-type: none"> ■ If possible  	 088244	
	<ul style="list-style-type: none"> ■ Or if not possible 	 109875 (Bracket) 104280 (Rivet)		
	<ul style="list-style-type: none"> ■ Or cracks in zinc layer 	 109875 (Bracket) 104280 (Rivet)		
	33.40.28 Cover	<ul style="list-style-type: none"> ■ Missing  		
	<ul style="list-style-type: none"> ■ Or broken 	 110561 (Cover) 125661 (Screw)		

PERI Rental Criteria

Industrial Scaffolding



UH Spigot Ledger to Ledger Coupler	Nr.	Description	Article number
--------------------------------------	-----	-------------	----------------

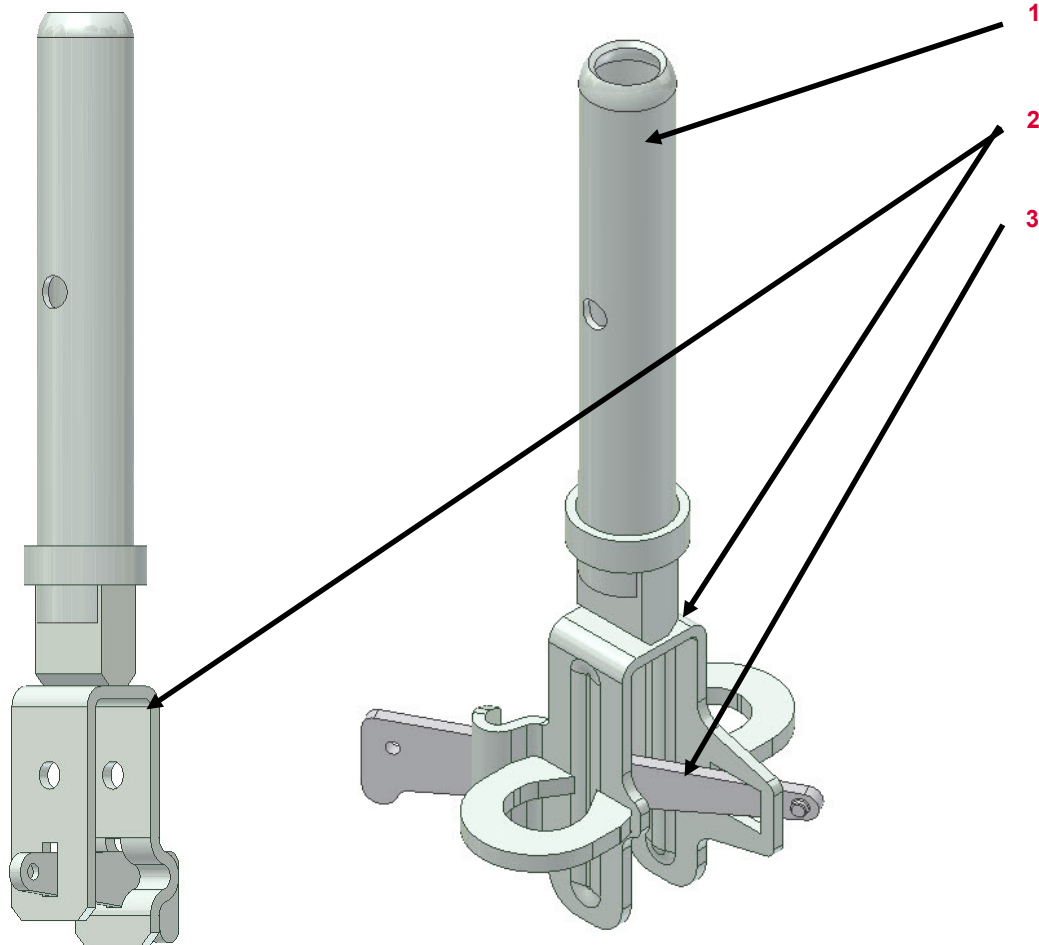

1	Spigot	
2	Bracket	
3	Wedge	

Valid for	Item number
UH- Spigot	109764
UH- Spigot-2	130681
Ledger to Ledger Coupler UHA	101731
Ledger to Ledger Coupler UHA Half	110793
Ledger to Ledger Coupler UHA half with spigot	110792
Ledger to Ledger Coupler UHA-2 half with spigot	130684

PERI Rental Criteria

Industrial Scaffolding



UH Spigot Ledger to Ledger Coupler	Description	Instruction	Billing condition	Type
--------------------------------------	-------------	-------------	-------------------	------



33.40.29 Spigot bent | dented



33.40.30 Hook bent

■ If possible and no cracks in zinc layer



088244











■ Or if no longer possible



PERI Rental Criteria

Industrial Scaffolding



Ladder Connection UAC-2 (124813)	Description	Instruction	Billing condition	Type
	<p>33.40.31 Local dent in profile</p> <ul style="list-style-type: none"> ■ Edges not affected 			
	<p>33.40.32 Wedge torn out missing</p>			

PERI Rental Criteria

Industrial Scaffolding



Ladder Connection UAC-2 (124813)	Description	Instruction	Billing condition	Type
----------------------------------	-------------	-------------	-------------------	------



33.40.33 Profile bent at edge

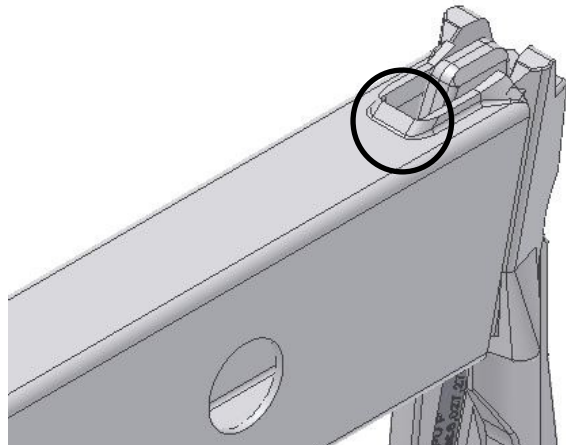

33.40.34 Dent at hook

- If possible



088244



- Or if not possible



















- Or crack in material

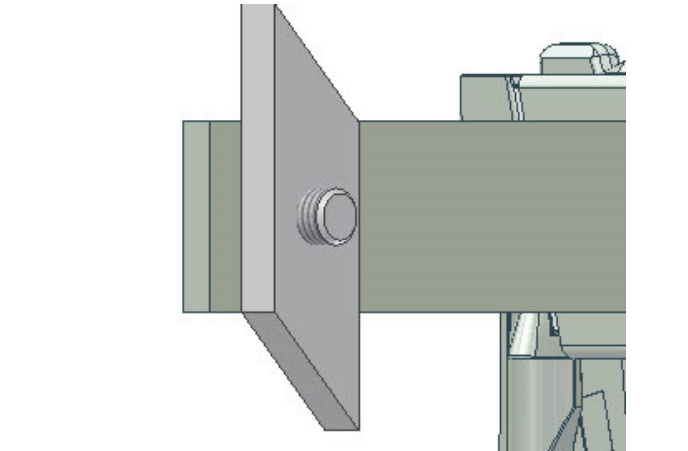

PERI Rental Criteria

Industrial Scaffolding













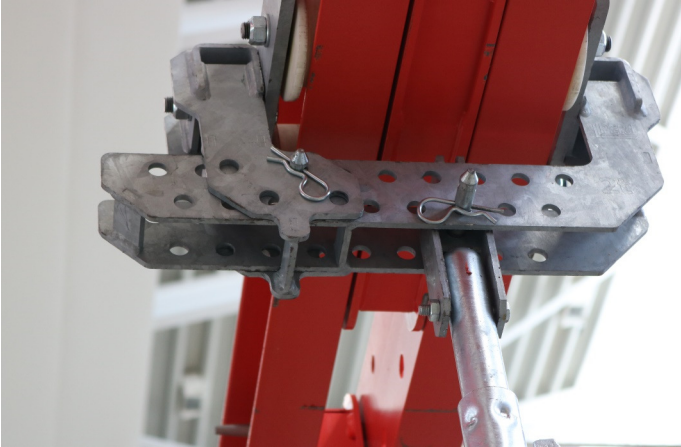

Ladder Connection UAC-2 (124813)	Description	Instruction	Billing condition	Type
	33.40.35 Hole dented			
	<ul style="list-style-type: none"> ■ If original geometry of hole unchanged 		 088244	
	<ul style="list-style-type: none"> ■ Or if changed 			
	<ul style="list-style-type: none"> ■ Or cracks in material 			
	33.40.36 Clamping plate			
	<ul style="list-style-type: none"> ■ Missing 		 701763 (Clamping plate) 710266 (Bolt)	
	<ul style="list-style-type: none"> ■ Or not movable 		 701763 (Clamping plate) 710266 (Bolt)	

PERI Rental Criteria

Industrial Scaffolding









Trolley UFS 20 (126497)	Description	Instruction	Billing condition	Type
	33.40.37 Flanged Wheel <ul style="list-style-type: none"> ■ Timeworn 	 127436 (Flanged Wheel)		
	<ul style="list-style-type: none"> ■ Damaged due to violence 	 127436 (Flanged Wheel)		
	33.40.38 Bolt Cotter pin <ul style="list-style-type: none"> ■ Missing 	 018050 (Bolt) 018060 (Spring pin)		
	<ul style="list-style-type: none"> ■ Unusable due to violence 	 018050 (Bolt) 018060 (Spring pin)		

PERI Rental Criteria

Industrial Scaffolding



Trolley UFS 20 (126497)	Description	Instruction	Billing condition	Type
	33.40.39 Spigot connection bent	<ul style="list-style-type: none"> <li data-bbox="875 568 1249 595">■ If possible (connection possible)  	 088244 	
	<ul style="list-style-type: none"> <li data-bbox="875 711 1084 738">■ Or if not possible 	 127447 (Spigot connection)	 	

PERI Rental Criteria

Industrial Scaffolding



Additional Element End Element ULS Flex	Nr.	Description	Article number
---	-----	-------------	----------------

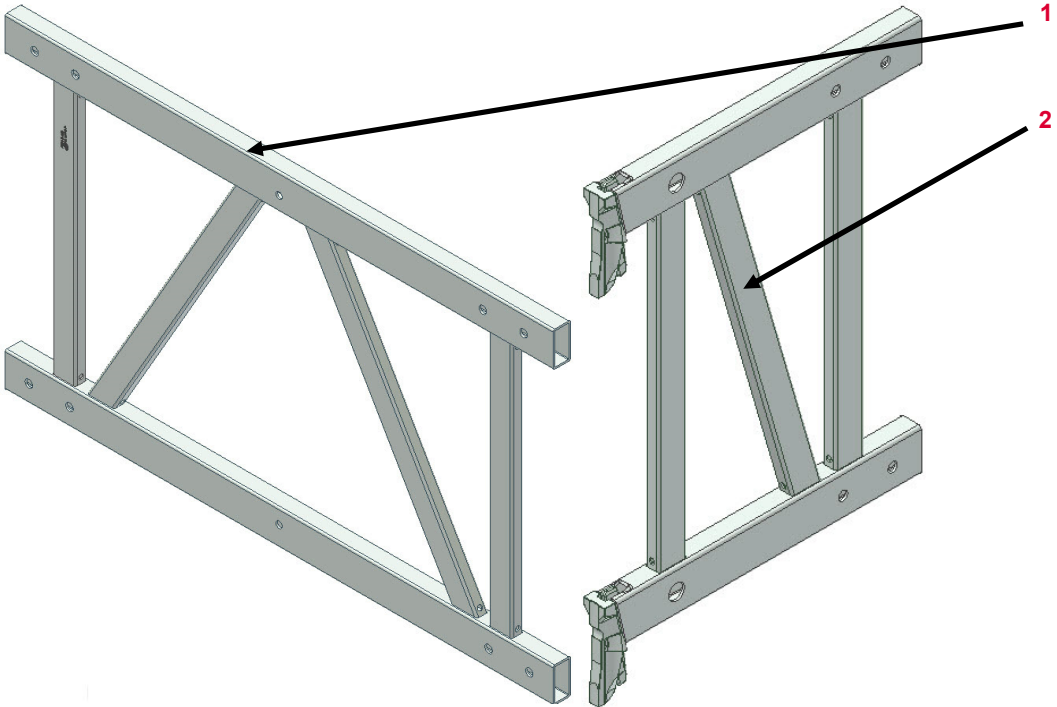

















- 1 Frame
- 2 Strut

Valid for	Item number
Additional Element ULS 100 FLEX	124795
Additional Element ULS 125 FLEX	124790
Additional Element ULS 150 FLEX	124781
End Element ULS 50 FLEX	124805

PERI Rental Criteria

Industrial Scaffolding

















Additional Element End Element ULS Flex	Description	Instruction	Billing condition	Type
	<p>33.40.40 Elements bent dented at junction</p> <ul style="list-style-type: none"> ■ If possible and bolts are able to be put through ■ Or no longer possible ■ Or cracks in zinc layer 	<ul style="list-style-type: none">   	<ul style="list-style-type: none">  088244  	<ul style="list-style-type: none">  
	<p>33.40.41 Frame strut bent</p> <ul style="list-style-type: none"> ■ Functionality given ■ Or functionality no longer given ■ Or bent 	<ul style="list-style-type: none">    	<ul style="list-style-type: none">    	<ul style="list-style-type: none">   

PERI Rental Criteria

Industrial Scaffolding



















Connector ULS Flex (124806)	Description	Instruction	Billing condition	Type
	<p>33.40.42 Junctions bent</p> <ul style="list-style-type: none"> ■ If possible and bolts are able to be put through ■ Or no longer possible ■ Or cracks in zinc layer 	<p>    </p>	<p>  088244  </p>	<p>   </p>
	<p>33.40.43 Bolt / Cotter pin</p> <ul style="list-style-type: none"> ■ Missing ■ Unusable due to violence 	<p>  018060 (Cotter pin) 124771 (Bolt)  018060 (Cotter pin) 124771 (Bolt) </p>	<p>   </p>	<p>   </p>

PERI Rental Criteria

Glossary Icons



Icon	Significance	Icon	Significance	Icon	Significance
	Not Ok– material is scrap		Billing necessary (customer)		Optical damage
	OK– material stays in rental park		No Billing necessary		Functional damage
	Scrap material– it's not permitted to hand out the material because of safety aspects		Shorten the material		Functional damage— it's not permitted to hand out the material
	Repair according to instruction		Mark the material		Static damage— it's not permitted to hand out the material
	Fix material cold– Afterwards check weld seams and bordering components		Replace damaged material		
	Repair after local economic efficiency calculation		Replace missing material		
	Clean the material				