

GRIDFLEX

Aluminium Grid Slab Formwork

Assembly Instructions for Standard Configuration

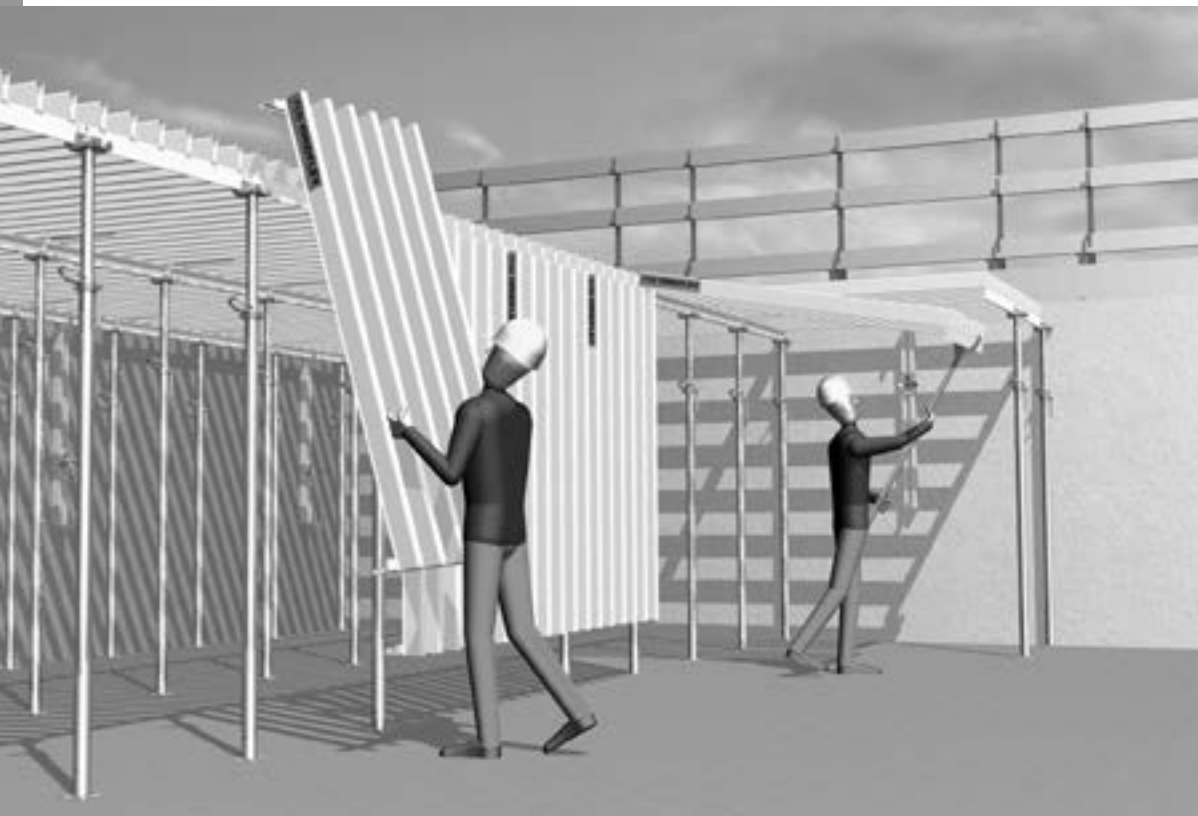

Contents

Overview		
Overview		1
Introduction		
Standard configuration		2
Intended use		2
Safety instructions		3
Additional PERI product information		3
A Standard configuration		
A1 Storage and transportation		4
A2 System components		8
A3 Shuttering		
Start field		10
First row		11
Second row		12
Additional rows		13
A4 Infills		
Transverse infill		14
Longitudinal infill		15
Longitudinal and transverse infills		16
A5 Shuttering around columns		17
A6 Cantilevers, Guardrails		18
A7 Installation of plywood formlining		21
A8 Working and concreting scaffold		23
A9 Striking		27
A10 Maintenance and cleaning		28
Tables		
Prop Loads, Evenness		29
Slab Props PERI PEP 10, 20, 30		30
Components		
Components		34

Key



Safety instructions



Note



Visual Check



Tip

Overview

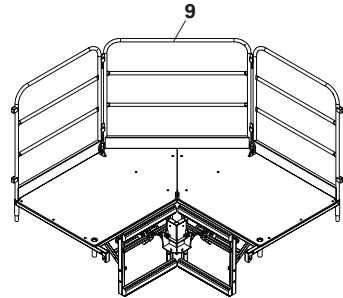
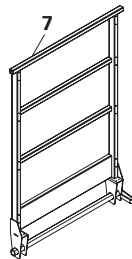
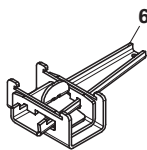
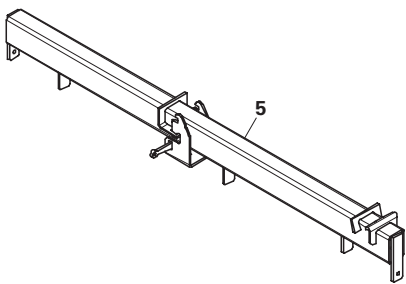
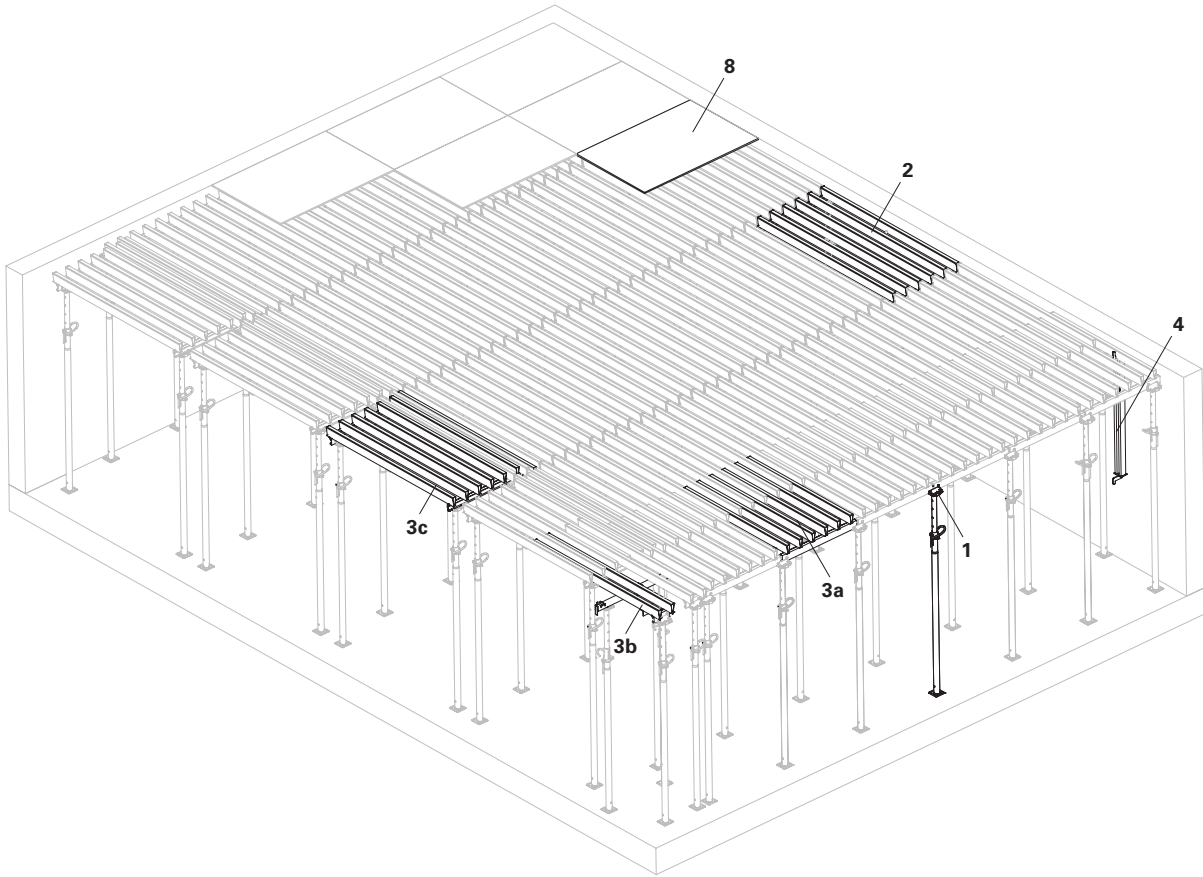

- | | | | |
|----|---|----|--|
| 1 | Prophead GFH | 4 | Wall Holder GFW |
| 2 | Standard Element
GFP 200 x 100 (white) | 5 | Traverse GF 100 |
| 3a | Filler Element Longitudinal
GFL 150 x 100 (yellow) | 6 | Clamp GFK |
| 3b | Filler Element Longitudinal
GFL 183 x 20 (yellow) | 7 | Guardrail GF |
| 3c | Filler Element Cross
GFC 200 x 100 (red) | 8 | Plywood Formliner e. g.
1500 x 1000 x 15 mm |
| | | 9 | Corner Platform GCP,
complete |
| | | 10 | Platform GIP 200, complete |

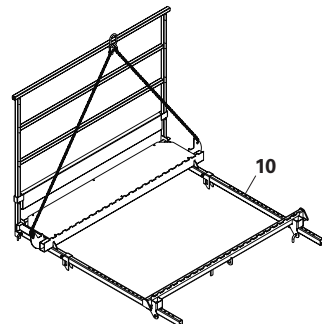

Introduction

Standard configuration

General

The structures presented in these assembly instructions are shown in the form of examples with only one component size. They are valid accordingly for all component sizes contained in the standard configuration.

Features

PERI GRIDFLEX is a flexible girder grid slab formwork made of aluminium for slab thicknesses up to 67 cm.

The formwork consists of propheads and standard elements. For the infill areas, telescopic filler elements are available.

The elements are made of aluminium and thus very light. The area of application for the elements is indicated through the coloured powder coating.

A range of accessories for the slab edges is also available.

The formwork is safely assembled from below.

The formwork has been optimised for a 15 mm thick plywood formliner.

Deflection without centre support in a standard field

Slab thickness $d = 20$ cm: $l/500$

Slab thickness $d = 26$ cm: $l/400$

Slab thickness $d = 33$ cm: $l/300$

Main components

- Prop Head GF
- Standard Element GFP (white)
- Filler Element Cross GFC (red)
- Filler Element Longitudinal (yellow)
- Safety installations

Technical data

Permissible slab thicknesses and available prop loads: see PERI Design Tables.

System dimensions

Slab thicknesses up to 33 cm

2.00 x 1.00 m (shown in the following)

Slab thicknesses up to 67 cm

1.00 x 1.00 m

Intended use

1. PERI products are exclusively designed as technical work equipment which is intended only for commercial use by suitably qualified site personnel.

2. These assembly instructions serve as basis for a structure-related risk evaluation and instructions for the supply and use of the system by the contractor (user). However, they do not replace these.

3. Only PERI original components may be used. The use of other products and spare parts represent a misapplication with associated safety risks.

4. The components are to be inspected before each use to ensure that they are in perfect condition and function correctly.

5. PERI components may not be altered in any way and represents a misapplication with associated safety risks.

6. Safety instructions and permissible loads must be observed at all times.

7. Components provided by the contractor must correspond to the characteristic features required in these assembly instructions as well as all current laws and standards.

In particular, the following apply if nothing else is specified:

- timber components: Strength Class C24 for Solid Wood EN 338.
- scaffold tubes: galvanised steel tubes with minimum dimensions of $\varnothing 48,3 \times 3,2$ mm according to EN 12811-1:2003 4.2.1.2.
- scaffold tube couplings according to EN 74.

8. Deviations from the standard configuration may only be carried out after a separate risk assessment has been done by the contractor (user). On this basis, appropriate measures for the working safety and stability are to be implemented.

Introduction

Safety instructions

General

1. Deviations from the standard configuration and/or intended use present a potential safety risk.
2. All country-specific laws, standards and other safety regulations are to be taken into account when our products are used.
3. During unfavourable weather conditions, suitable precautions and measures are to be taken in order to guarantee working safety and stability.
4. The contractor (user) must ensure the stability throughout all phases of construction. He must ensure and verify that all occurring loads are safely transferred.
5. The contractor has to provide safe working areas for site personnel which are to be reached via safe access means. Areas of risk must be cordoned off and clearly marked. Hatches and openings on accessible working areas must be kept closed during working operations.
6. In order to ensure better understandability, detailed descriptions are partly incomplete. The safety installations which have possibly not been shown in these detailed descriptions must nevertheless be available.

Storage and transportation

1. Do not drop the components.
2. Store and transport components so that no unintentional change in their position is possible. Detach lifting gear from the lowered units only if these are in a stable position and no unintentional change is possible.
3. When moving, components are to be picked up and set down so that any unintentional toppling over, falling apart, slipping or rolling is avoided.
4. Use only suitable load-carrying equipment to move the components as well as the designated load-bearing points.
5. During the lifting and moving procedure, ensure all loose parts are removed or secured.
6. During the moving procedure, always use a guide rope.
7. Move components only on clean, flat and sufficiently load-bearing surfaces.

System-specific

1. Retract components only when the concrete has sufficiently hardened and the person in charge has given the go-ahead for striking to take place.
2. Anchoring is to take place only if the anchorage has sufficient concrete strength.
3. During striking, do not tear off the formwork elements with the crane.
4. The existing prop loads (see tables) must be safely transferred by means of sufficiently load-bearing slab props or tower systems.
5. GRIDFLEX platforms are classified in Load Class 2 (permissible load of 150 kg/m²). They are available as working and safety scaffold.
6. If heavy objects are supported on the formwork, the load-bearing capacity must be taken into consideration.
7. Cantilevers may only be accessed after bracing has been mounted.
8. The horizontal fixed position of the slab formwork must be guaranteed. This is given with circumferential walls and pre-concreted beams. Otherwise the transfer of the horizontal loads must be guaranteed by means of other measures supplied by the contractor, e.g. bracing.
Load assumptions for horizontal loads in accordance with DIN EN 12812.

Additional PERI product information

- GRIDFLEX brochure
- PERI design tables
- “Instructions for Use” for pallet lifting trolley
- “Instructions for Use” for pallets and stacking devices

A1 Storage and transportation



PERI stacking devices and pallets may not be used if the type plate is missing or illegible!

Inspection and fixing of new identification markings is to be carried out exclusively by PERI!

Only elements of the same size may be stacked and transported as a unit. Manually-created transport units must be correctly stacked and secured!

Pallets and stacked components are to be protected against the effects of the weather, e.g. secure elements by means of tension straps against lifting!

For storing and transporting GRIDFLEX components, the following pallets and stacking devices are used:

- Stacking Pallet GF, galv. (14)
- Pallet RP 80 x 110 (15)
- Pallet GF 85 x 210, galv. (16)
- Pallet Cage 80 x 120 (17)

Storage

- Pallets are to be stacked on clean, flat and sufficiently load-bearing surfaces.
- Storage time is maximum 24 months.
- The selected reference dynamic pressure is 0.39 kN/m² according to DIN 1055-4:2005-03.
- For temporary storage, insert two Stacking Pallets GF into each other.

Transporting loads

PERI pallets and stacking devices are suitable for lifting with a crane or forklift. They can also be moved using the PERI Pallet Lifting Trolley.

- 4-sling lifting gear is always attached to the four load attachment points.
- Only one pallet is moved at any one time with the crane.

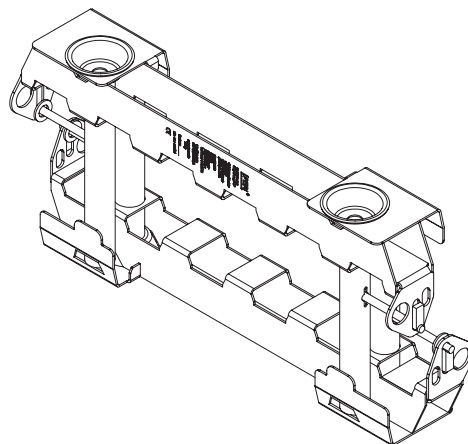
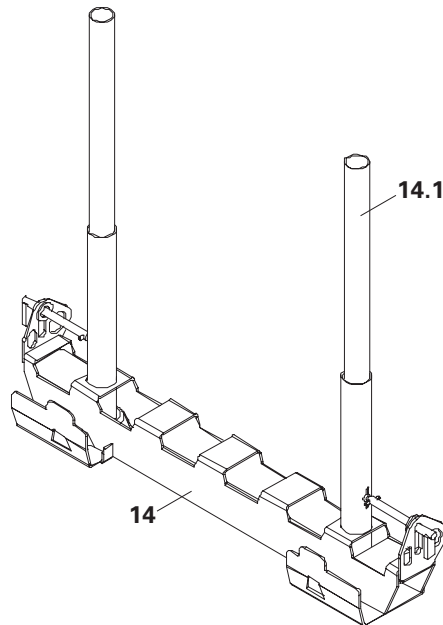

A1 Storage and transportation

Stacking Pallet GF

Permissible load-bearing capacity

175 kg/piece.

Length of 4-sling lifting gear: min. 3.0 m.

The Stacking Pallet GF is designed to carry GRIDFLEX Elements GFP, GFC and GFL.

For preventing damage during transportation, always stack an even number of elements and tension the tension belt over the Tension Strap Rails GF 92, GF 125 (14.3).

Stacking height

- 1 Free-standing pallet.
- 2 Pallet positioned with longitudinal side against the wall or pyramidally stacked.

Filling

1. Position two Stacking Pallets GF (14) corresponding to the element length. The support take-ups (14.2) must be pointing outwards.
 2. Remove pins.
 3. Insert the first element with the cross profiles pointing downwards.
 4. Lay the second element with the cross profiles pointing upwards in the first element.
 5. Insert pins and tighten securely.
 6. Fit additional elements - alternatively turned in other direction.
- Secure with Pallet Extension GF 10 (14.1).

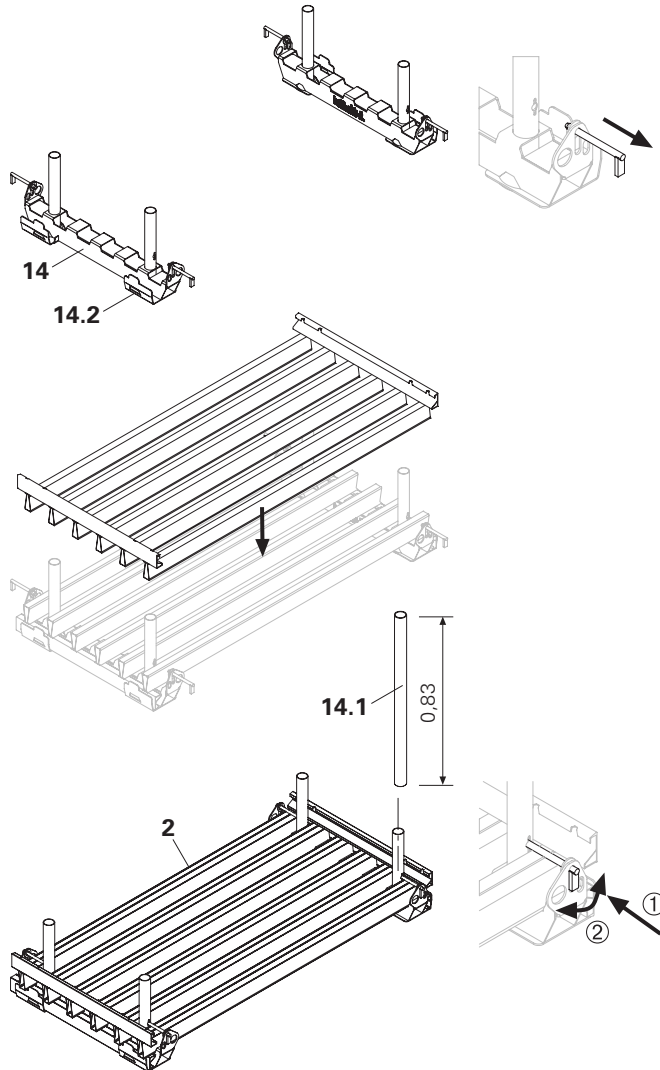

When stacking the Filler Elements GFC, the lifting chains must be positioned inside of the rectangular tube.

10 x Standard Element GFP 200 x 100
10 x Filler Element GFL 150 x 100

10 x Filler Element GFC 200 x 100

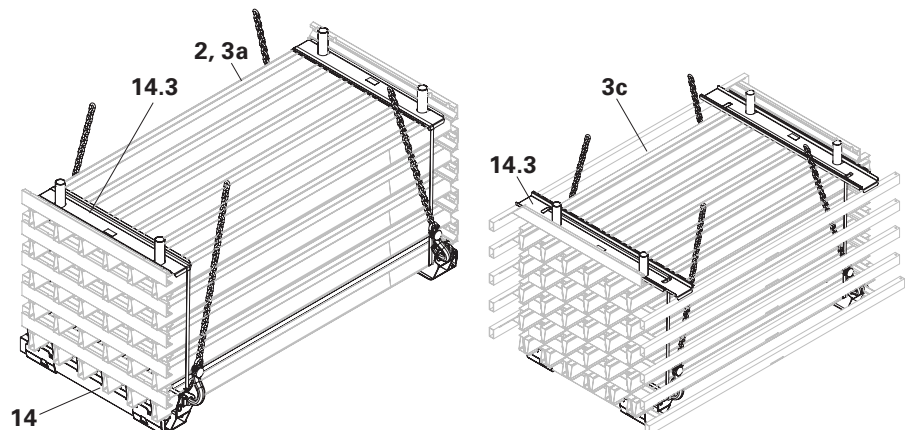

A1 Storage and transportation

Pallet Cage 80 x 120

Permissible load capacity 1500 kg
Length of 4-sling lifting gear min. 3.0 m.

The Pallet Cage 80 x 120 (17) is used to store e.g. GRIDFLEX Propheads.



Take into consideration Instructions for Use for PERI pallets and stacking devices!

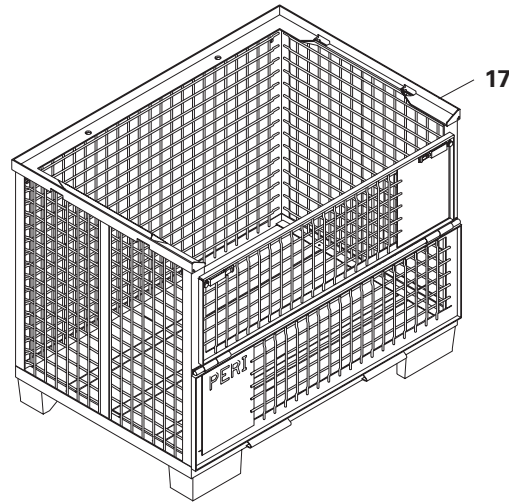

Pallet RP 80 x 110

Permissible load capacity 500 kg
Length of 4-sling lifting gear min. 3.0 m.

The Pallet RP 80 x 110 (15) is used exclusively for storing GRIDFLEX Guardrails GF 100 (7), maximum 12 pieces.

Stacking height

- Always use the same type of pallet when stacking.
- 5 pallets stacked in a free-standing position.
- 7 pallets with longitudinal sides positioned against the wall or stacked in combination.

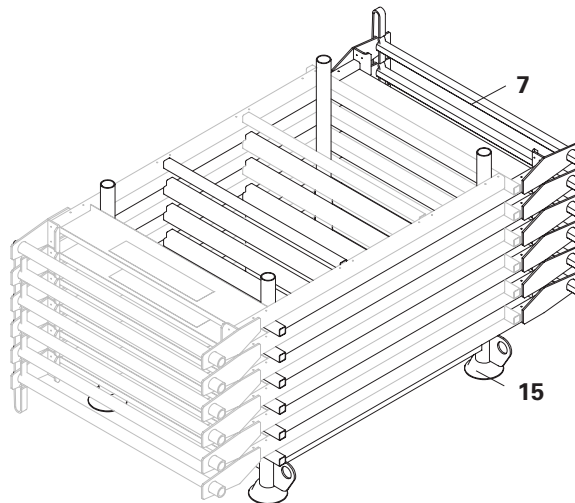

Pallet GF 85 x 210

Permissible load capacity 750 kg
Length of 4-sling lifting gear min. 3.0 m.

The Pallet GF 85 x 210 (16) is used exclusively for storing GRIDFLEX Filler Elements GFL 183 x 20 (3b), maximum 42 pieces.

Stacking height

- Always use the same type of pallet when stacking.
- 1 pallet in a free-standing position.
- 2 pallets with longitudinal sides positioned against the wall or stacked in combination.
- Adjust height of stacked items using timbers.

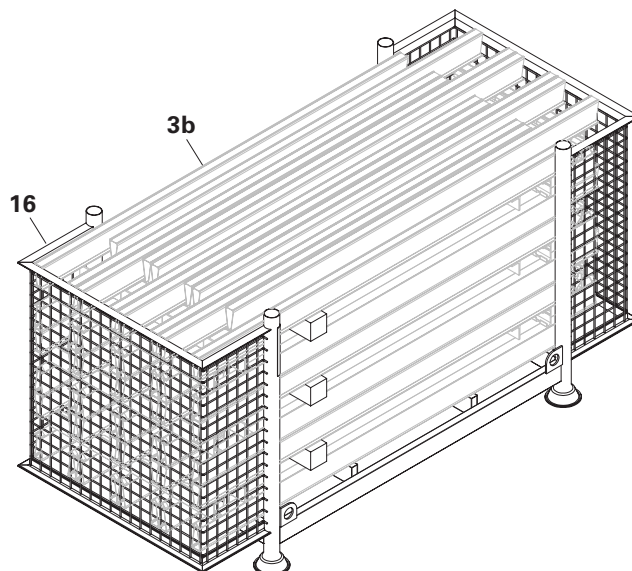

A1 Storage and transportation

EC Declaration of Conformity

in accordance with EC Directive 98/37/EC
Appendix II A

We hereby declare that the following product corresponds to the relevant, fundamental safety and health requirements of the respective EC Directive on the basis of its development and design, as well as the version available on the market. In the case of any changes made to the product which have not been agreed to by us, this declaration is no longer valid.

Stacking Pallet GF	Item no. 110939
Pallet RP 80 x 110	Item no. 111396
Pallet GF 85 x 210	Item no. 111738

Relevant EC Directives:

EC Machine Guidelines 98/37/EEC

Applied harmonised standards:

EN 13155

National standards and technical specifications applied:

DIN 1055, DIN 4421, DIN 18800, BGR 234, BGR 500

Weissenhorn, 01.09.2008



Dipl.-Ing. Manfred Rathfelder
Head of Research & Development

PERI GmbH
P.O. Box 12 64
89259 Weissenhorn
www.peri.com

A2 System components

Prophead GFH

This fits on props with end plates of max. 125 x 125 x 8 mm and a hole diameter of 30 - 40 mm.

With hole diameters > 40 mm, the prophead is to be mounted diagonally using 2 x countersunk bolts M10 x 25, DIN 7991 and nuts M10, DIN 7042-8.

Assembly

Push prophead (1) on to the end plate of the prop until it locks in position.

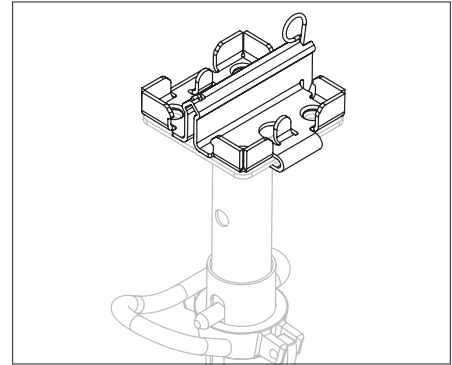
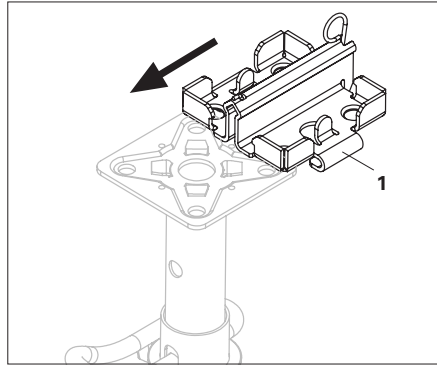

Spring retention is locked in position.

Insert elements from above (for falsework)

Use e.g. with PERI UP Head Spindle GTR 38-70/50. Turn prophead by 90°.



When installing from above, there is no anti-lifting measure.

Insert elements from below (standard design)

Use with slab props.

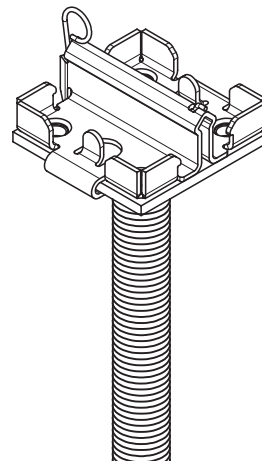
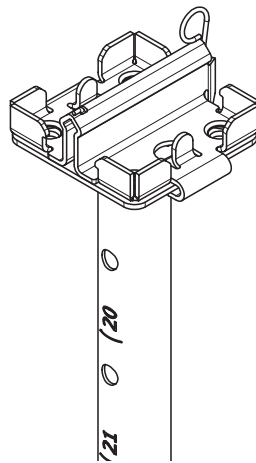

Extension length of the prop.

Calculations based on:

Clear ceiling height minus 184 mm minus thickness of formlining.

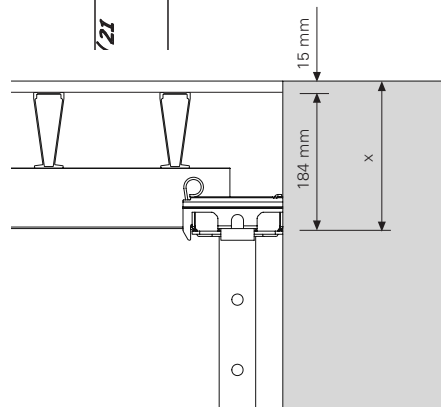

A2 System components

Wall Holder GFW



The area to be formed may not be accessed before the formwork has been horizontally anchored!

The Wall Holder GFW is used to hold the slab formwork in a horizontal position during assembly. It is mounted in longitudinal and lateral directions. Install Wall Holder GFW in the start field in both directions. Turn the respective Wall Holder End upwards. Install the Wall Holder GFW so that it can be adjusted.

Assembly

1. Push tie rod with Wingnut Pivot Plate through the available tie hole.
2. Bring Wall Holder GFW (4) in position and tension by means of the Wingnut Pivot Plate.
3. Cover protruding tie rods with protective caps.

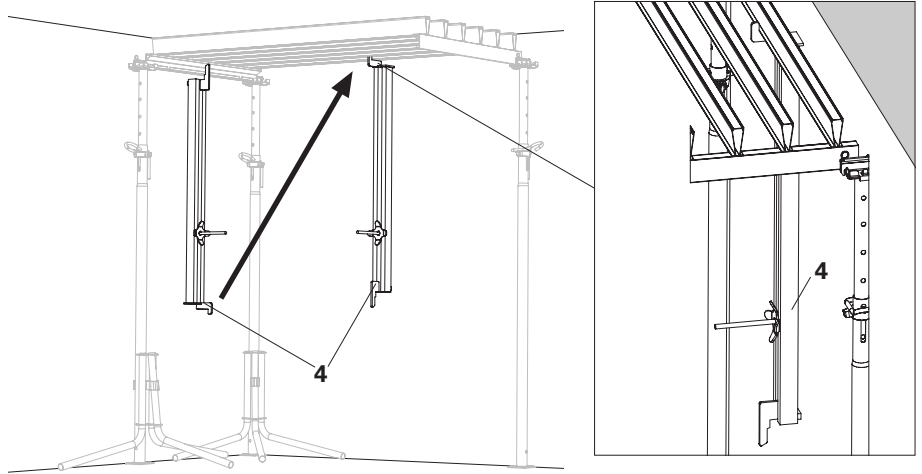

Shuttering Aid GFA

The Shuttering Aid GFA (11) is used for assembling and dismantling GRIDFLEX elements.

Adjustable in 7.5 cm increments.

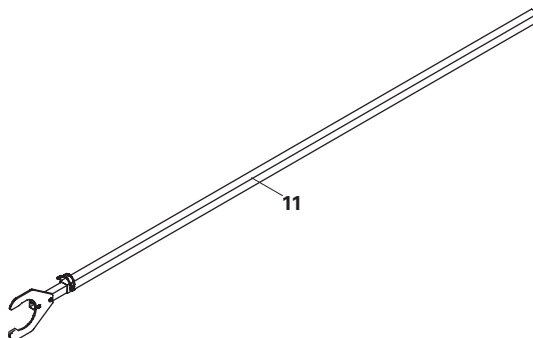

A3 Shuttering

General information

The illustrations and grid dimensions apply to slab thicknesses with $d \leq 33$ cm.

For slab thicknesses ≤ 67 cm: see Design Tables.

The longitudinal side of the element runs in the direction of the longer wall. Install props so that the G-hook can be accessed and secured without any difficulty.

Start field

1. Position two props with propheads (1) and secure with tripod, 1.0 m spacing.

2. Attach Standard Element GFP (2), white.

3. Swivel upwards using the shuttering aid (11) and set down on the shuttering aid itself.

4. Place third prop with prophead (1) at an angle on the element end from the inside and bring in a vertical position from the outside, 2.0 m spacing. Remove shuttering aid.

Remove shuttering aid.

The start field is complete.



As an alternative, the start field can also be braced using Frames PRK instead of with tripods.



Remove two pallet extensions to ensure easier removal of the elements from the pallet.

First row

- Tripods can be re-used on additional elements one at a time.
- Work always takes place one row after the other in a lateral direction.

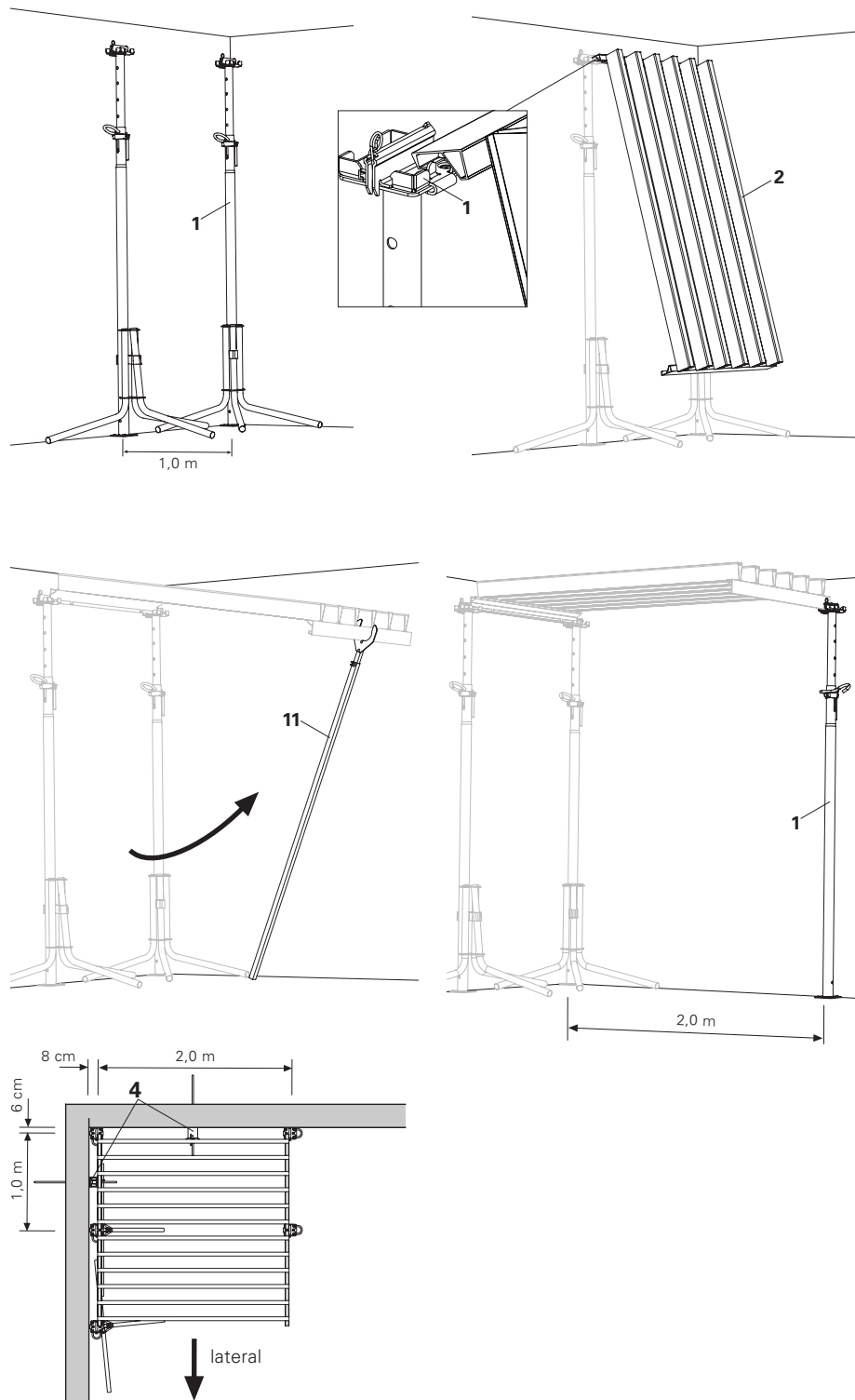

A3 Shuttering

First row

Install additional Standard Elements GFP (2) in the same way.



Install a Wall Holder GFW (4) in every third Standard Element (cross). Take into consideration the situation on site!

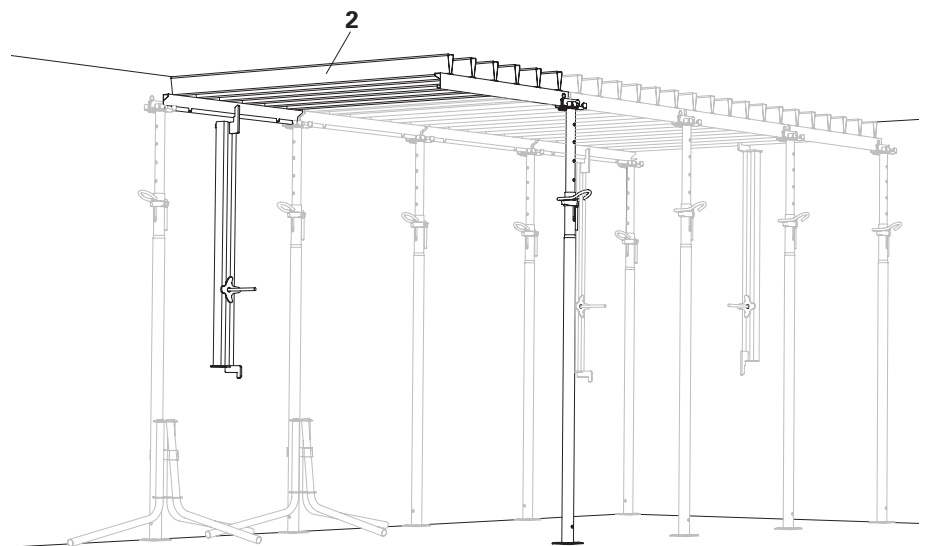
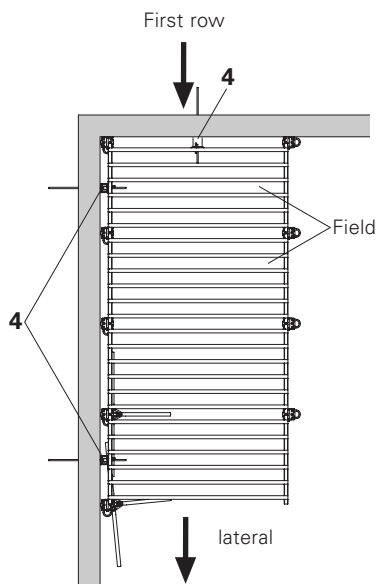
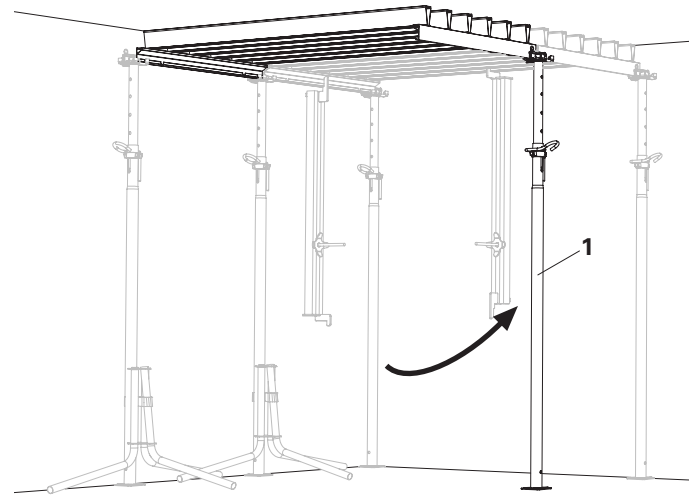
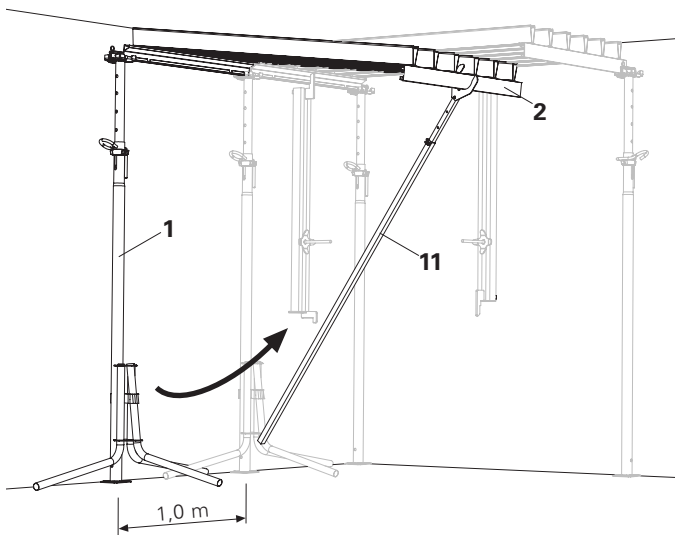

A3 Shuttering

Second row

1. Attach Standard Element GFP (2).

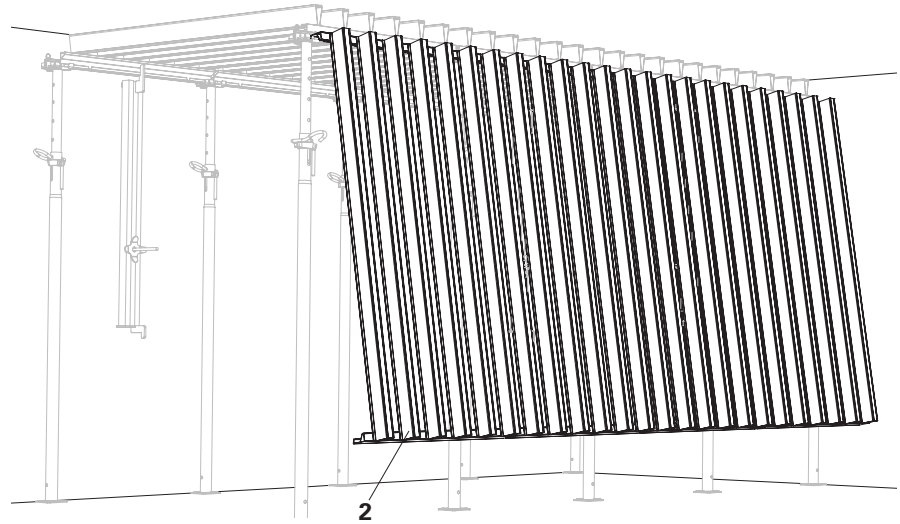

2. Swivel up the first Standard Element GFP with the Shuttering Aid GFA and set down on the shuttering aid itself.
 3. Place prop with prophead (1) at an angle on the element end from the inside and bring in a vertical position from the outside, 2.0 m spacing. Remove shuttering aid.

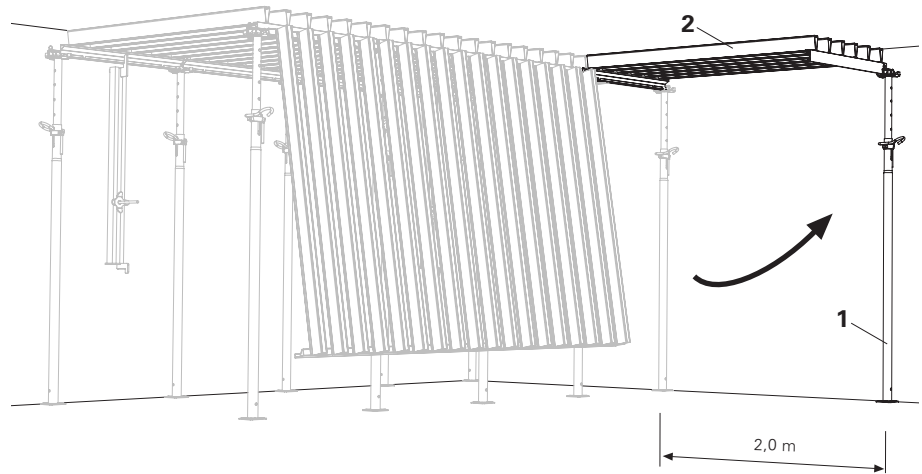

4. Swivel up the second Standard Element GFP with the Shuttering Aid GFA and set down on the shuttering aid itself.
 5. Swivel in prop with prophead (1) on the element end in both standard elements and bring in a vertical position.
 6. Assemble additional Standard Elements GFP (2) in the same way.

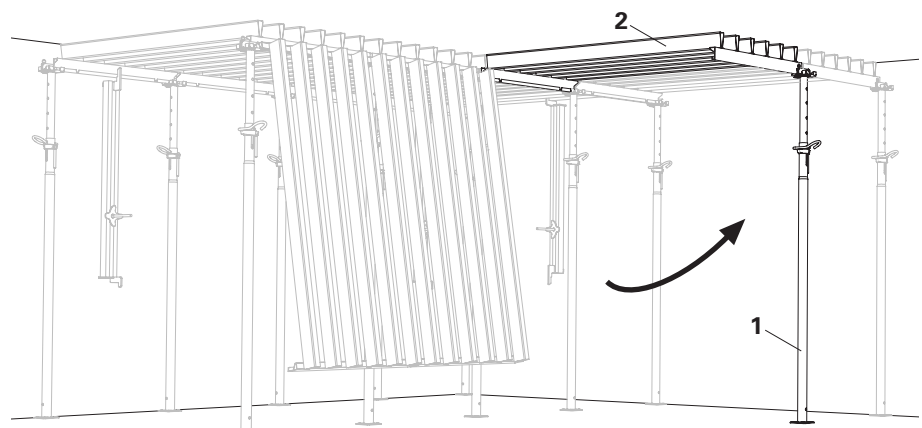

A3 Shuttering

Additional rows

- Due to the recurring assembly procedure, installation always takes place in the same way.
- Shuttering with the Standard Element GFP (2) is carried out up to the infill area.
- Position the last prop (1) on the Standard Element GFP (white) in front of the width compensation (see Infills A4).

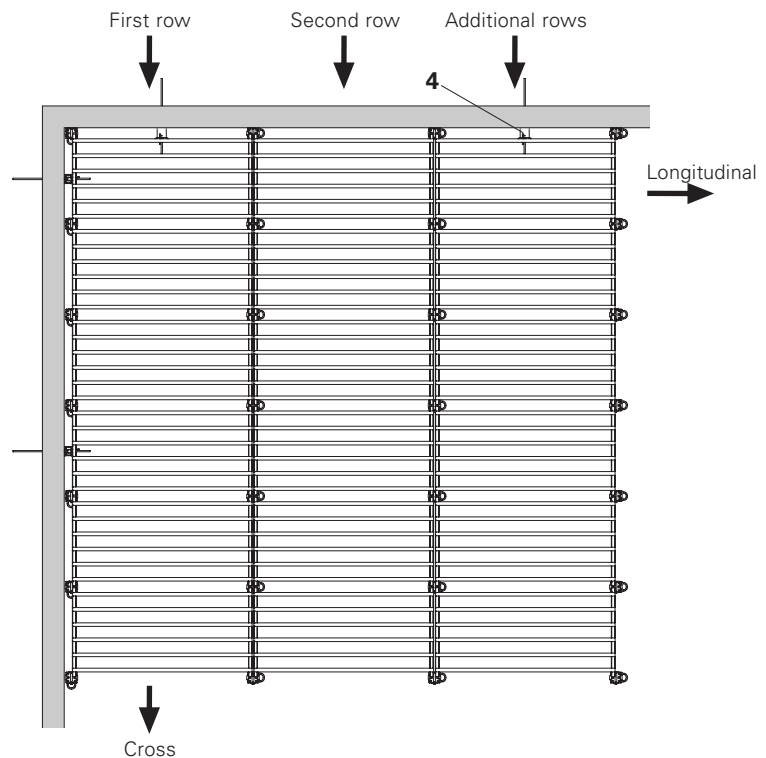
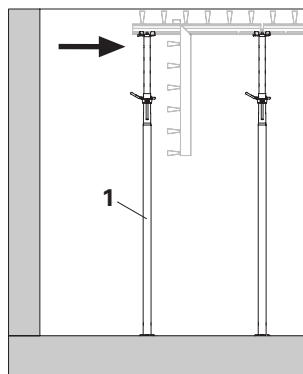
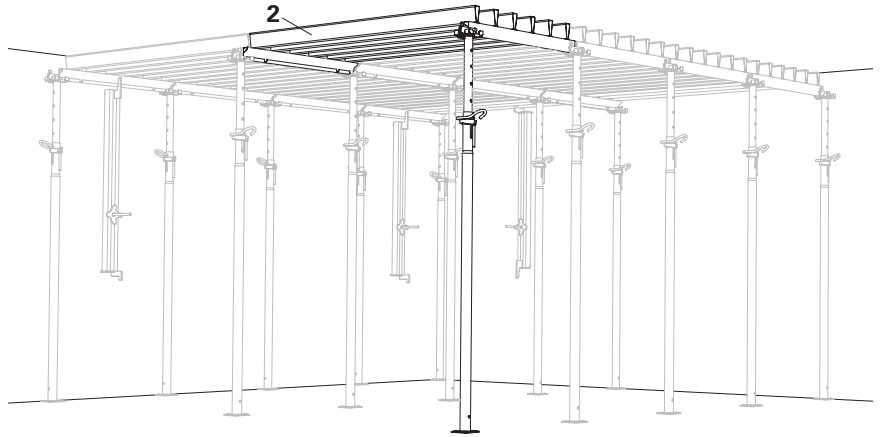

Install Wall Holder GFW (4) in every second row (longitudinal). Take into consideration the situation on site.



Ensure empty Stacking Pallet GF is available during striking.

A4 Infills

Width compensations up to 1.10 m With Filler Element GFC 200 x 100 (red)

1. With 6 cm or more compensation widths, attach Filler Element GFC (3c) between the longitudinal profiles of the Standard Elements GFP (2) within the area marked X.



At least one longitudinal profile must be overlapped!
Position protruding longitudinal profile (rectangular tube) of the Filler Element GFC (3c) on the lateral profile of the Standard Element GFP (2) - support L!

2. Swivel Filler Element GFC (3) upwards using the Shuttering Aid GFA and set down on the shuttering aid itself.

3. Swivel up forward-positioned props with propheads (1) and place in support take-up of the Filler Element GFC (3c).

4. Secure Filler Element GFC against moving - use 1 x Clamp GFK (6). Also possible in the slotted hole on the protruding main beam (rectangular tube).
Alternative: Wall Holder GFW.

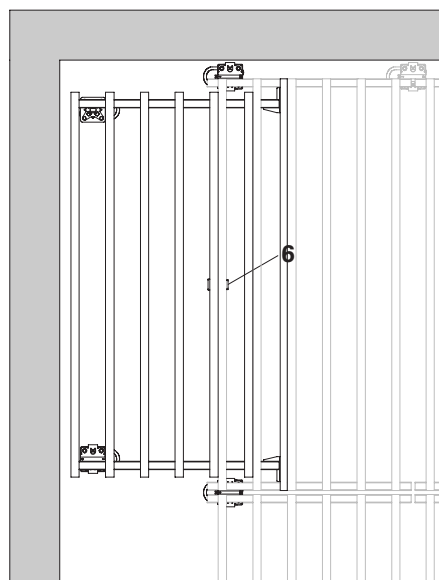
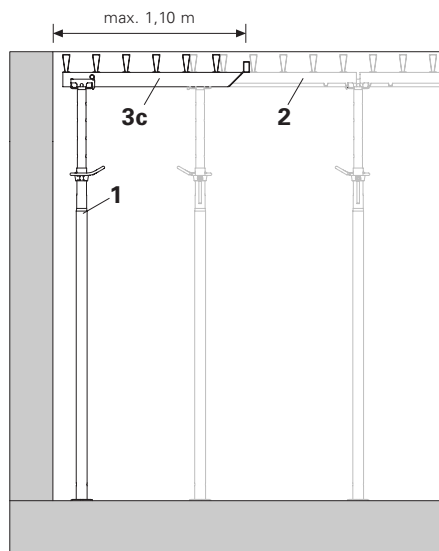
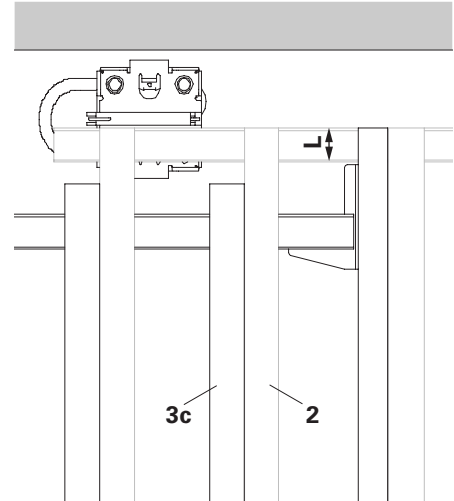
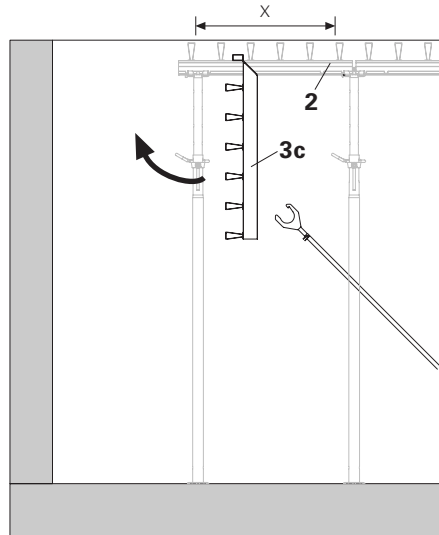

A4 Infills

Length compensation 0.30 - 1.30 m With Filler Element GFL 150 x 100 (yellow)

1. Install Traverse GF 100 (5) as assembly aid using the corresponding spacing in the overlap area on the Standard Element GFP (2):
 - from below, lift Traverse GF 100 against the profile, turn the claw in the direction of the profile and secure with a wedge.
2. Fit Filler Element GFL (3a) with the open end, swivel up and remain in position. Swivel up props with propheads and bring into a vertical position.
3. Secure Filler Element GFL against moving - use 1 x Clamp GFK (6).
Alternative: Wall Holder GFW.



If the hook cannot be engaged, turn the Traverse GF 100 by 180°.

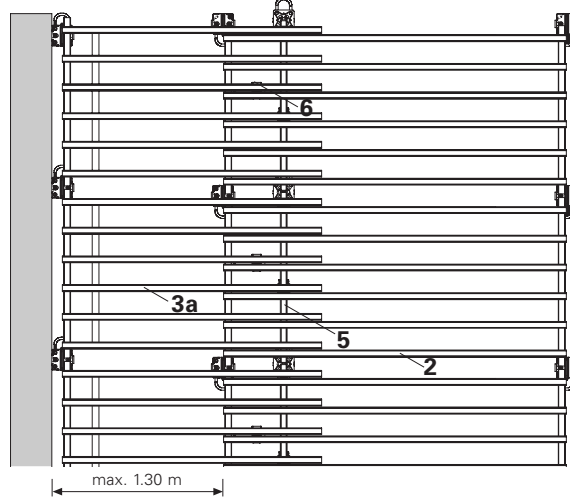
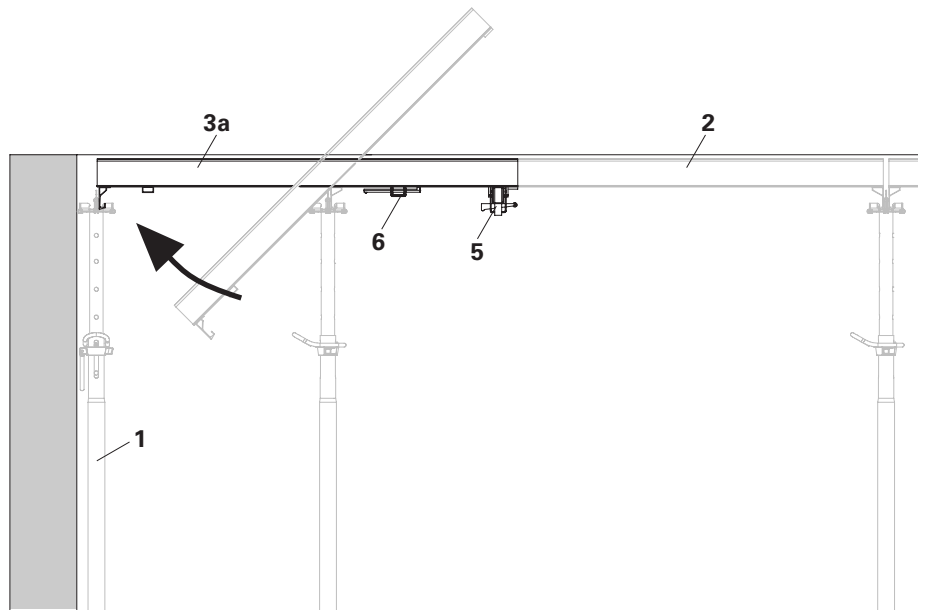

Length compensation up to 0.30 m

With Filler Element GFL 150 x 100 (yellow)

Turn the Filler Element GFL (3a) so that the open end is pointing towards the wall.

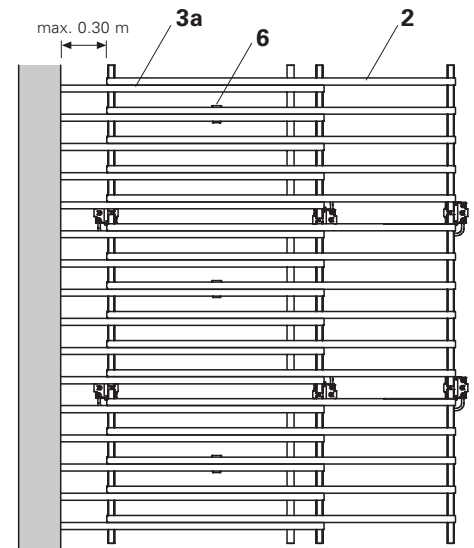
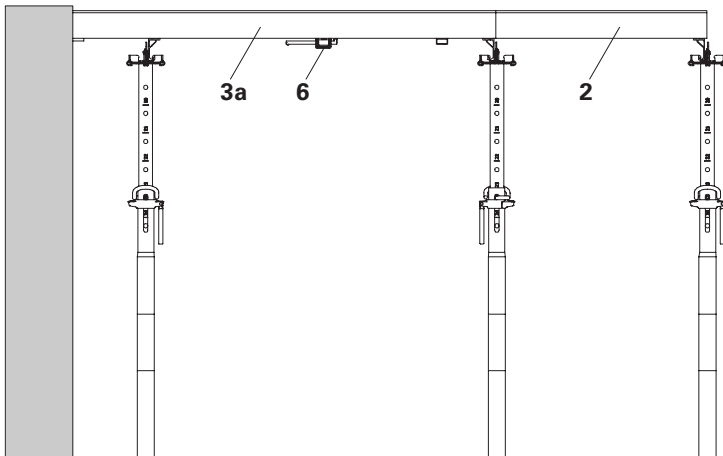

A4 Infills

Length compensation 1.30 - 2.10 m

1. Install Standard Element GFP (2) in a turned position to the assembled elements (see Assembly A2).
2. Close infill with the Filler Element GFC (3c).
3. Swivel up Filler Element GFC using the Shuttering Aid GFA.
4. Swivel up forward-positioned props with propheads (1) and fit in support take-up of the Filler Element GFC (3c).
5. Secure Filler Element GFC against moving by means of Clamp GFK (6). Also possible in the slotted hole on the protruding main beam (rectangular tube).

Alternative: Wall Holder GFW.

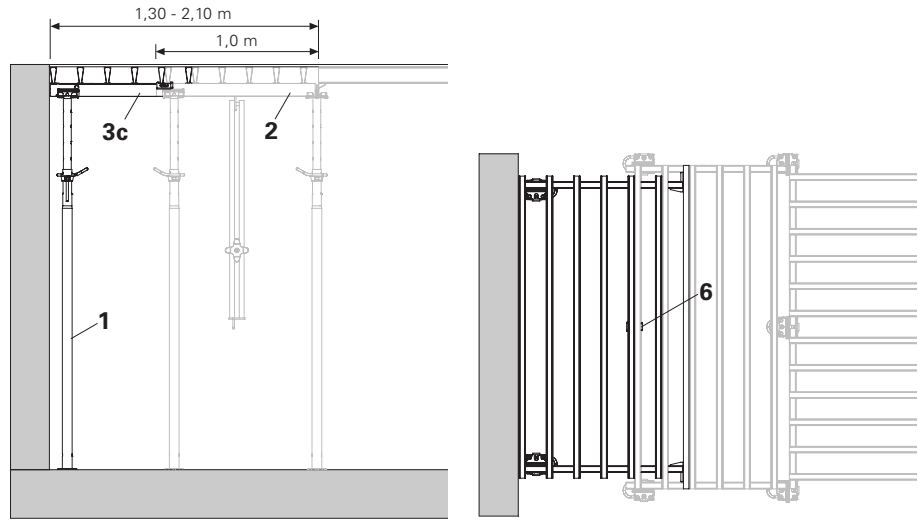

Length and width compensations in the corner area

The Filler Element GFC (3c) used for the width may not be additionally loaded through any length compensation. Therefore, loads from the longitudinal compensation are to be transferred via the Traverse GF 100 85) and props without propheads (1.1) on the Filler Element GFL (3a).

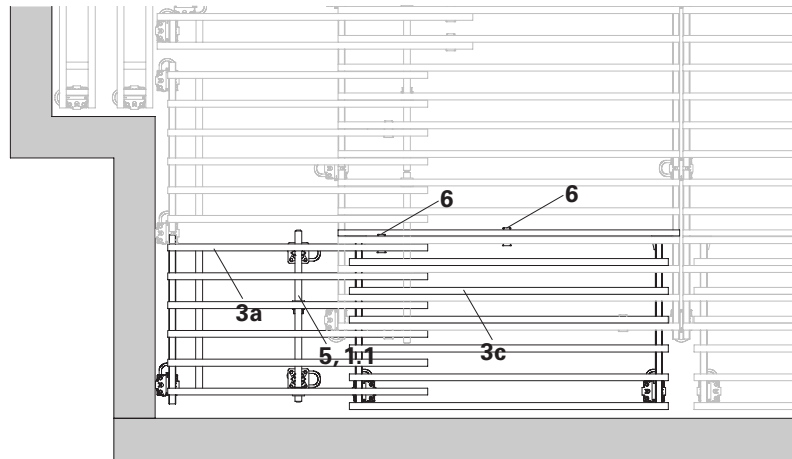

Filler Element GFL 183 x 20 (yellow)

1. Attach Filler Element GFL (3b) and swivel up.
2. Swivel up props with propheads (1) for each Filler Element GFL and bring in a vertical position.
3. Secure Filler Element GFL with 2 x Clamps GFK (6).



In the case of several Filler Elements GFL 183 x 20 next to each other, mount one clamp per GFL and Traverse.

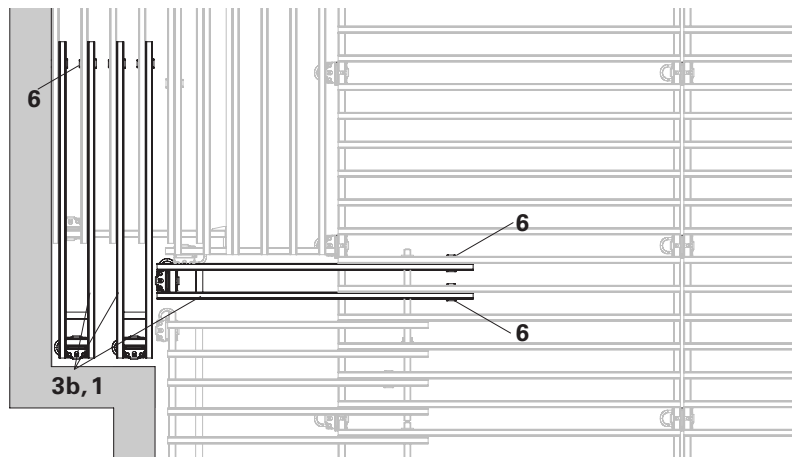

A5 Shuttering around columns

1 x recessed Standard Element GFP

- Filler Element GFI 150 x 100 (3a)
- Filler Element GFL 183 x 20 (3b)
- Clamp GFK (6)
- Traverse GF 100 (5) + prop without prophead (1.1)
- prop with prophead (1)

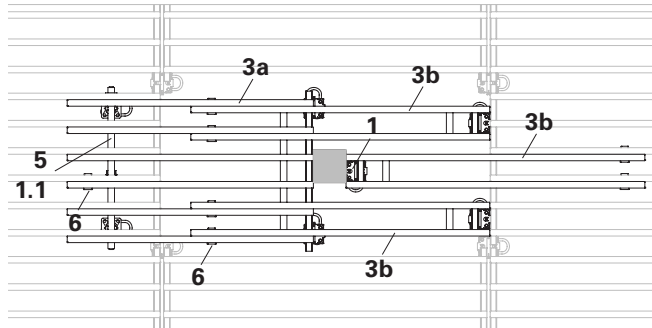

1 x recessed Standard Element GFP

- Filler Element GFC 200 x 100 (3c)
- Filler Element GFL 183 x 20 (3b)
- Clamp GFK (6)
- prop with prophead (1)

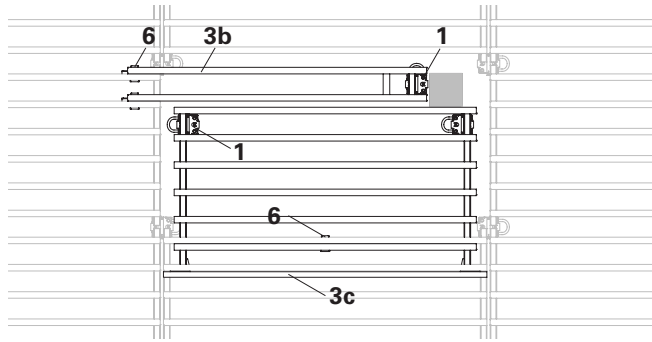

2 x recessed Standard Element GFP

- Filler Element GFC 200 x 100 (3c)
- Filler Element GFL 183 x 20 (3b)
- Clamp GFK (6)
- prop with prophead (1)

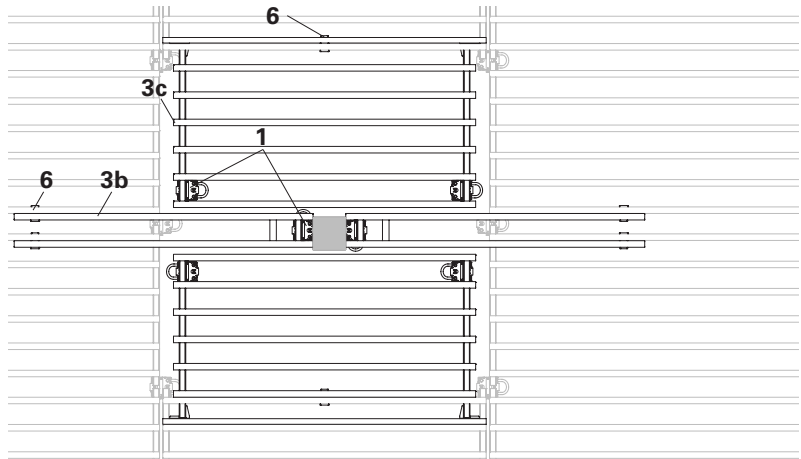

4 x recessed Standard Elements GFP

- Filler Element GFC 200 x 100 (3c)
- Filler Element GFL 183 x 20 (3b)
- Clamp GFK (6)
- prop with prophead (1)

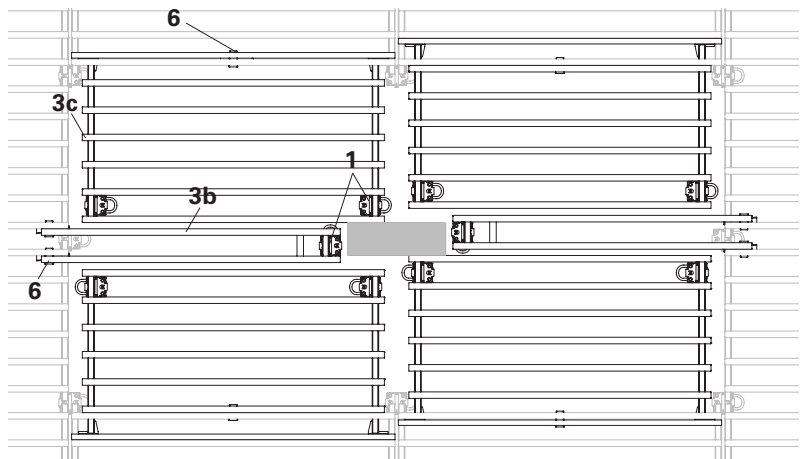

A6 Cantilevers, Guardrails

General



The area to be formed may not be accessed before the formwork has been horizontally anchored!
The cantilevers may not be accessed before the bracing has been form-locked mounted!

Key:

- Area of influence
e.g. slab $d = 26$ cm
- Bracing

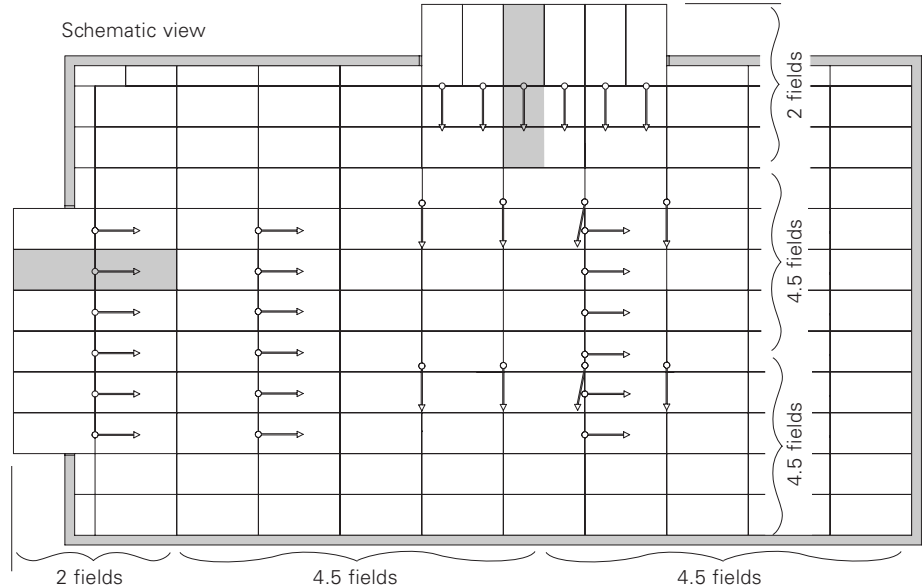

Bracing

- Ensure correct spacings
- Install longitudinal and lateral bracing in the fields
- Longitudinally with Tension Sleeve GFO (12)
- Laterally, chain wrapped around the cross beam

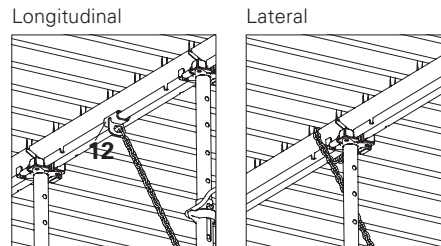

Cantilevers

Depending on the situation, the slab edge can be formed using different system components, e.g. with:

- Filler Element GFL 150 x 100 (3a)
- Guardrail GF (7)
- Traverse GF 100 (5) + prop without prophead (1.1)
- Bracing (12.1)

or

- Standard Element GFP 200 x 100 (2)
- Guardrail GF (7)
- Traverse GF 100 (5) + prop without prophead (1.1)
- Bracing (12.1)

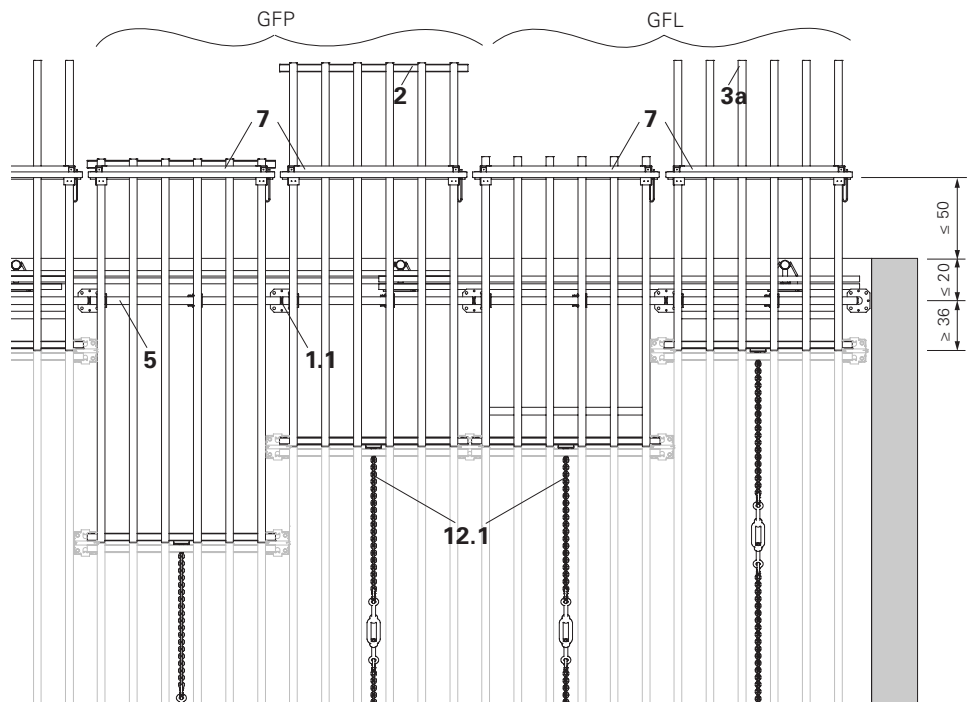

A6 Cantilevers, Guardrails

On building edges

As safety equipment, the Standard Element GFP (2) or Filler Element GFL 150 x 100 (3a) together with Guardrail GF can be used.

Prepare element with guardrail

1. Pull out tube (7.1) on the Guardrail GF (7).
2. Place guardrail on the element. With Filler Element GFL to the open side.
3. Push in tube and then secure the guardrail by turning the tube on the grip.
4. Nail the guardrail to the element.
4. Measure the prop spacing on the edge of the building and mount the Traverse GF 100 (5) accordingly.

Installation

1. Mount Base Plate RS with appropriate fixing means (e.g. PERI Multi Monti). The permissible chain tensile force is 3 kN.
2. Attach rope (12.2) to the middle of the inner cross profile of the element (7).
3. Attach element (7) to the propheads (1).
4. Run the rope over the outer cross profile of the last Standard Element GFP (2) and secure the unit.
5. Attach Tension Sleeve GFO (12) to the middle of the inner cross profile of the element.
6. Attach Anchor Chain (12.1) and fix with Turnbuckle.

Bracing consists of:

- Tension Sleeve GFO
- Anchor Chain
- Turnbuckle
- Base Plate RS

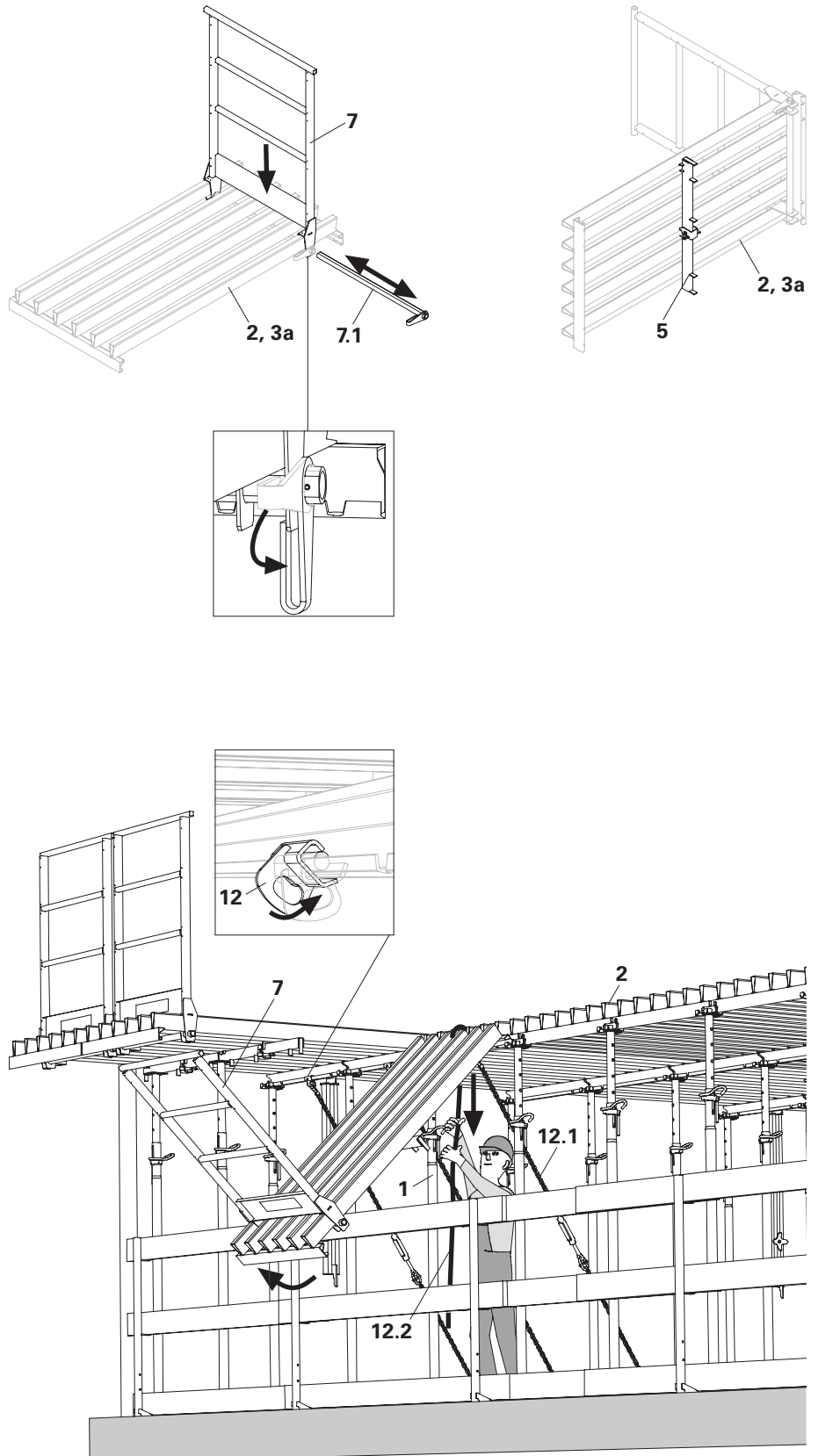

A6 Cantilevers, Guardrails

7. Swivel up guardrail unit (7) on the Traverse GF 100 (5) using the Shuttering Aid GFA (11).
8. Take up and support two Traverse GF 100 with the prop without prophead (1.1).
9. Remove rope.

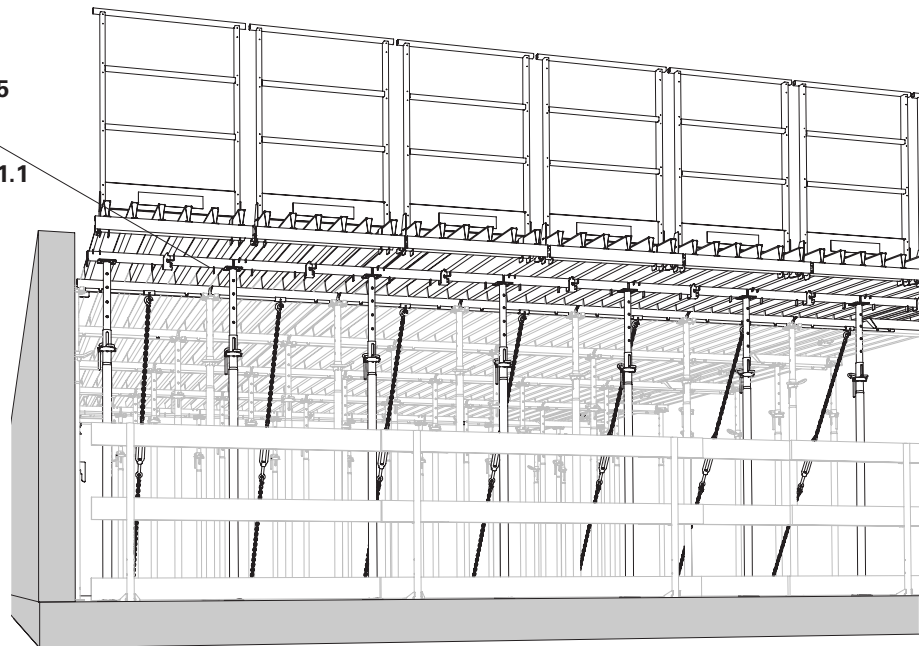
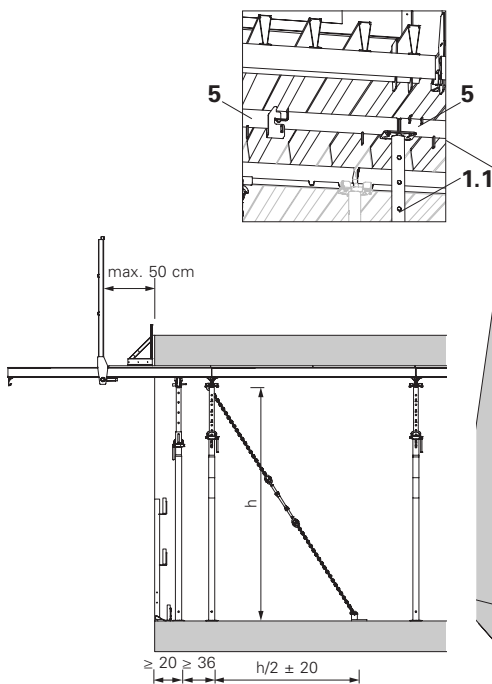
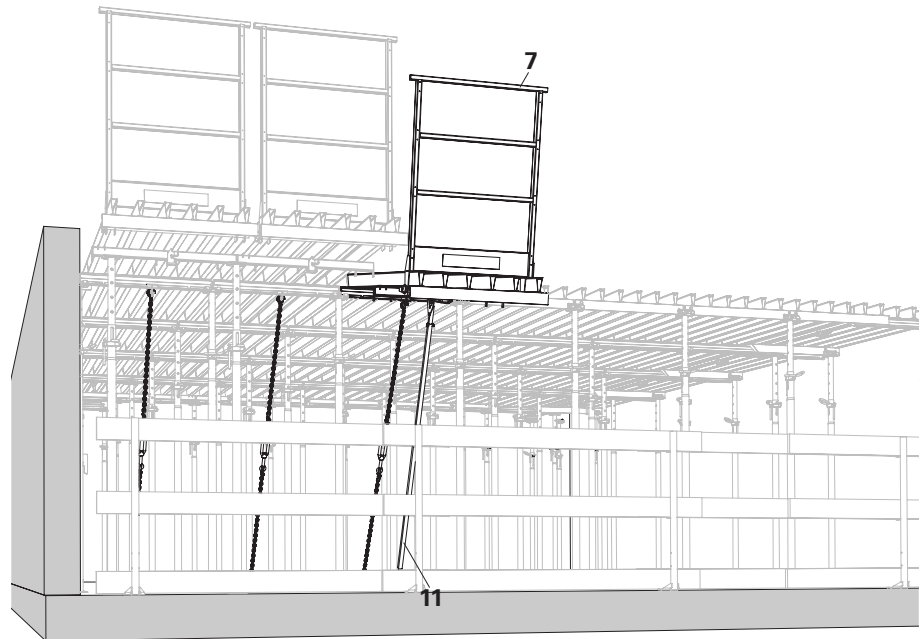

On the casting segments

Mount the guardrail unit (7) as described in "Preparing Element with Guardrail".

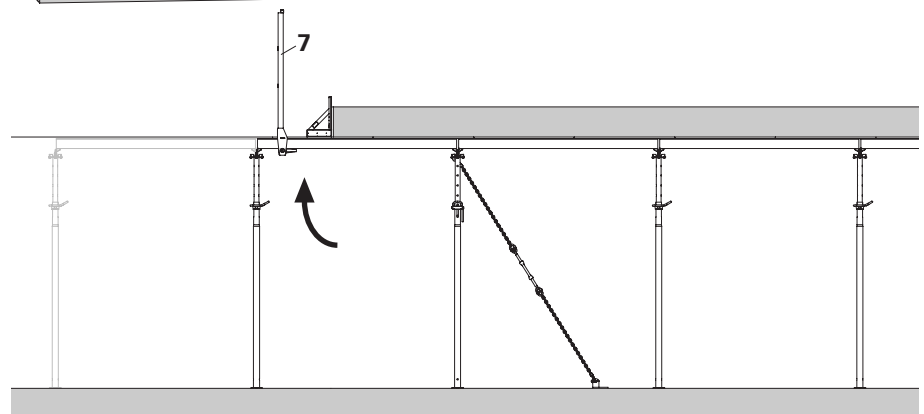

A7 Installation of plywood formlining

Standard configuration

Plywood formlining 1500 x 1000 x 15 mm with screwnails 2.0/2.2 x 25.

Alternative

Plywood formlining 1500 x 1000 x 21 mm with screwnails 2.0/2.2 x 33 (e.g. Trurnit) for fixing to the longitudinal profile.



Installation of plywood formlining:

- after shuttering the elements, after assembly of all guardrails and after levelling.
- install plywood formlining (8) always laterally to the Standard Element (makes striking easier).
- secure plywood formlining with screwnails immediately after installation.
- always install one row after the other including infill areas.

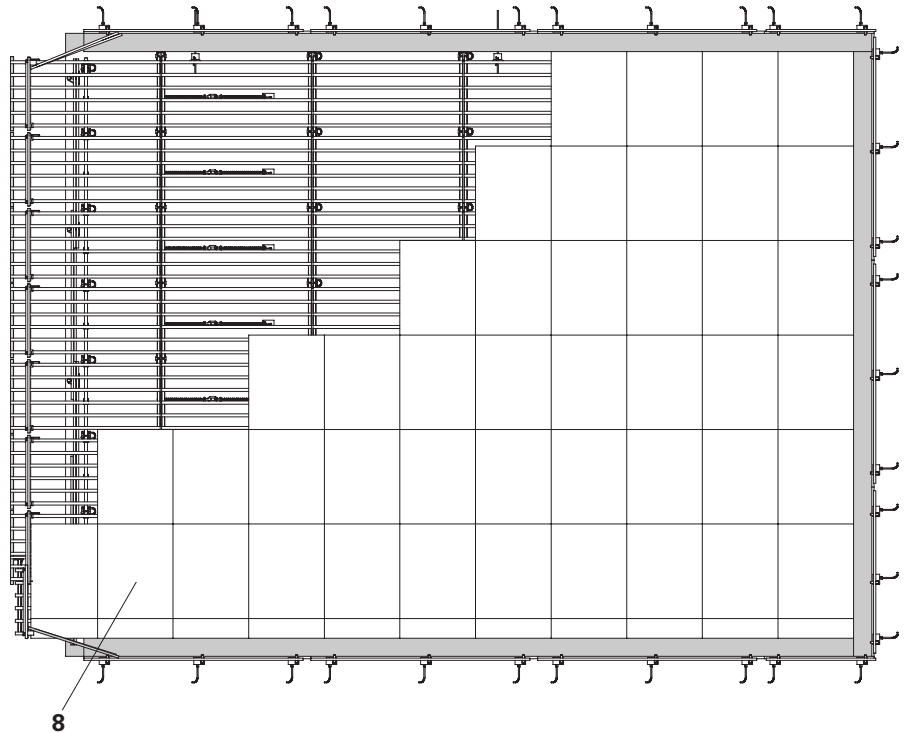

Fixing the plywood formlining:

in closed areas

1 x screwnail/m²

On open building edges

5 x screwnails/linear metre on both plywood sheets of the last joint which bridges the gap between the standard field and braced cantilever element. For the remaining area, see "in closed areas".



Levelling aid (13) with a T-piece, e.g. a strip of plywood.

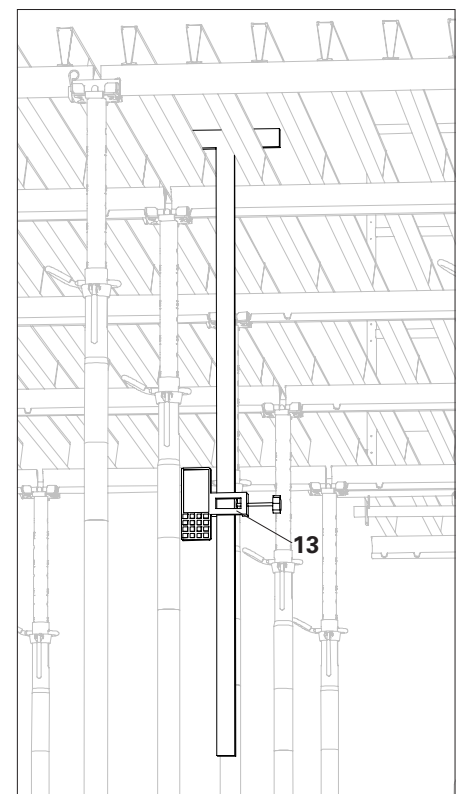

A7 Installation of plywood formlining

With increased requirements on the underside of the slab.

– additional fixing of the plywood formlining with nails:

As temperature and moisture level differences could occur between the top and bottom sides of the plywood formlining, we recommend that the plywood is nailed down at the corners.

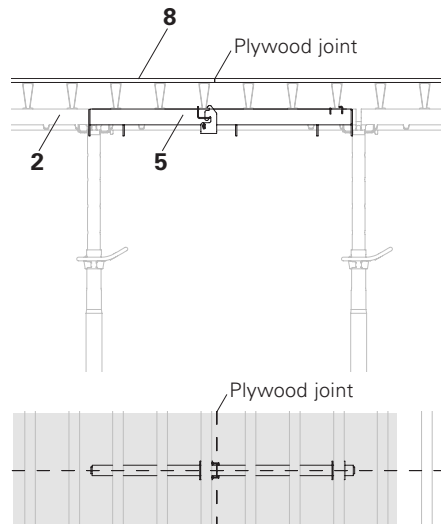

– additional element support with Traverse GF 100 in order to prevent offsets:

In the field

Attach Traverse GF 100 (5) to the Standard Element GFP (2) in the main beam with the least amount of plywood formlining overhang.

In the edge areas

Support the Standard Element GFP (2) in the middle using the Traverse GF 100 (5) and prop without prophead (1.1) in close proximity to the wall.

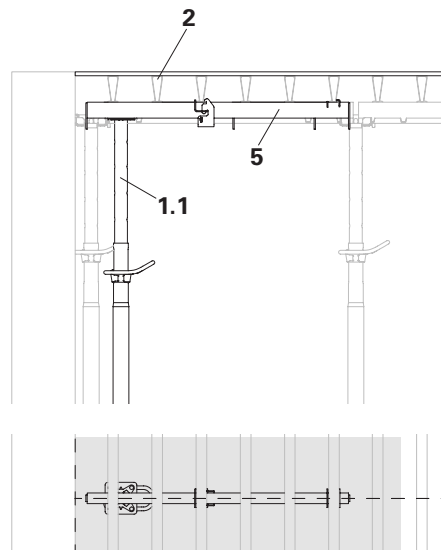

In infill areas

With narrow width compensations and high slab loads, provide support in the middle with Traverse GF 100 (5) and two props without propheads (1.1).

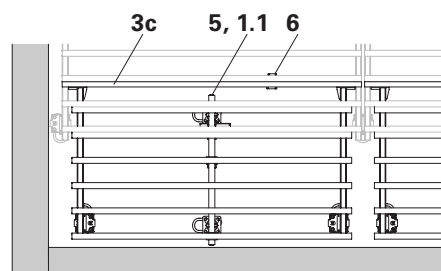

A8 Working and concreting scaffold

Corner Platform GCP

Permissible load 150 kg/m²

Corner Platform GCP (9) for circular and cornered columns with cross-sections from 20 - 50 cm on the building corners.

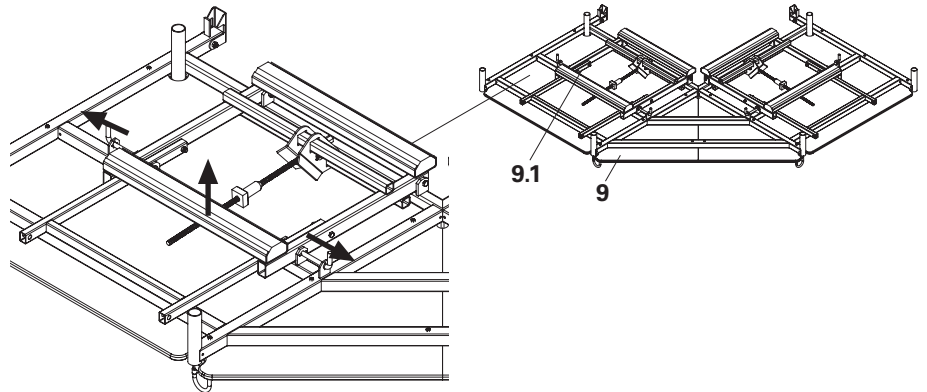

Preparing the platforms

1. Fold out supports (9.1) and lock in place.
2. Turn platform around, attach 3-sling lifting gear and lift.
3. Insert Platform Guardrail (9.2) and connect with each other.

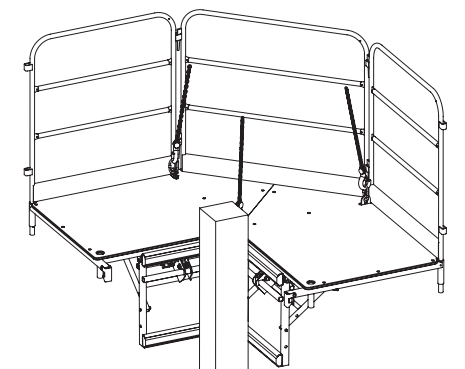
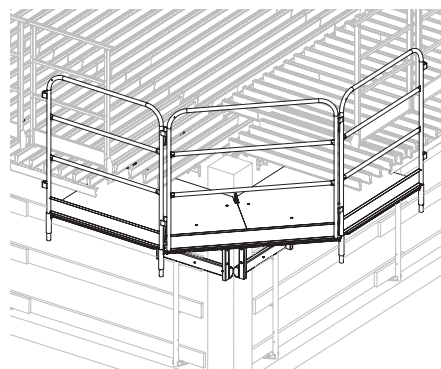
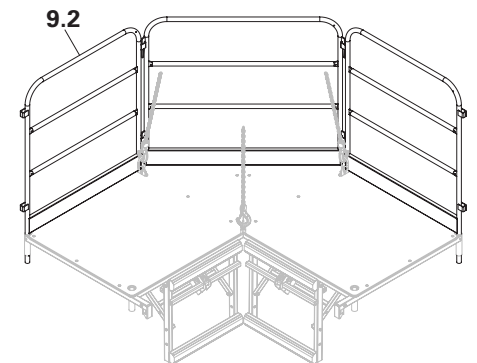
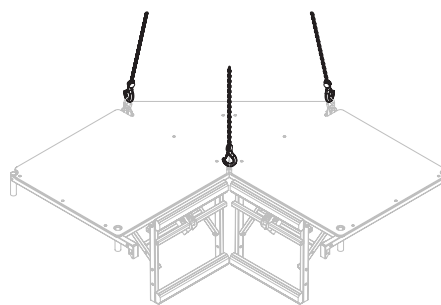
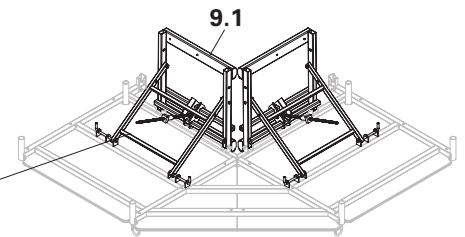
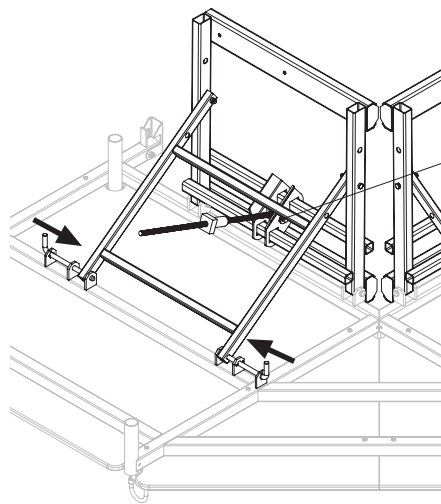

A8 Working and concreting scaffold

Assembling the platforms to the column

The corner platform must hang below the already installed slab formwork.

1. Pre-adjust the length of the props accordingly.

Extension length of the prop = clear height - 43.5 cm - plywood thickness.

2. Mount Internal Angle GCP (9.4) on the prop (2pcs M12 x 40 ISO 4016-4.6 MU), then position against the column and secure.
3. Position corner platform.
4. Install tie rod in Internal Angle GCP (9.4) and lightly tension.
5. Adjust height of corner platform and prop, and then tighten tie rods (9.3), SW 24.



Depending on the cross-section and concrete strength of the column, the corner platform must be braced inwards.

The platform produces additional moments of up to 5 kNm.

6. Place props on the right and left of the platform.
7. Remove lifting gear from the slab formwork position.

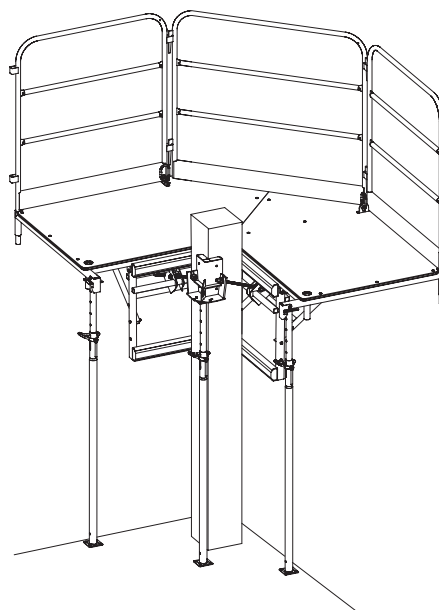
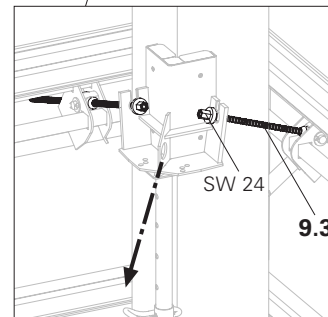
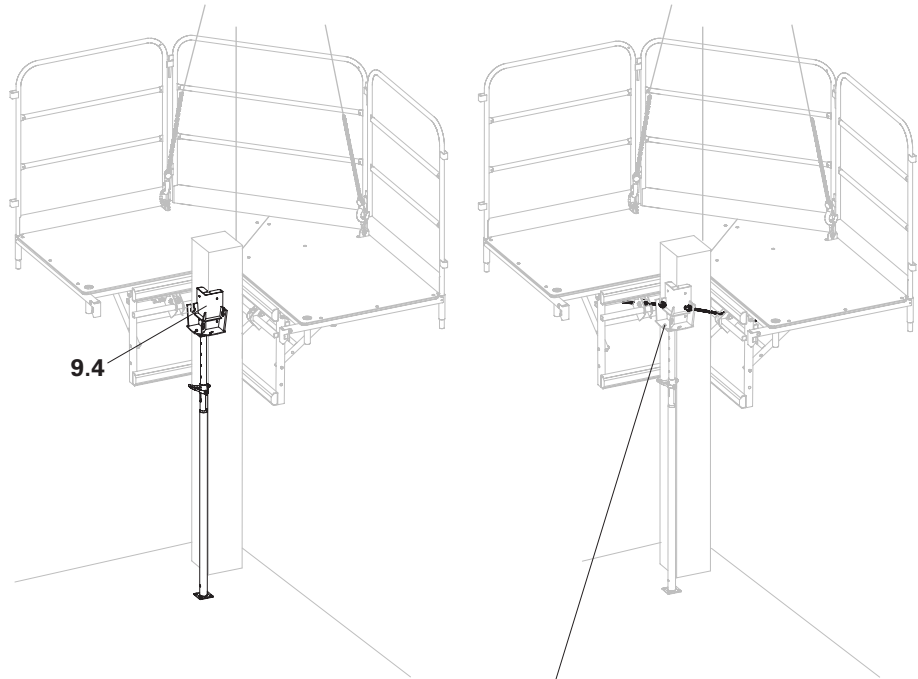

A8 Working and concreting scaffold

Platform GIP 200

Permissible load capacity of 150 kg/m²

Use Platform GIP (10) in connection with Filler Element GFL 183 x 20. The platform is used on interruptions such as columns.

Assembling the platform

1. Place Main Beam (10.1) on timbers.
2. Slide Cross Beam (10.2) on both Main Beams and fix (5 cm increments). Adjust prop spacing (L) - see Installation of Platform.

Prop spacing $L = X$ minus 12 cm

3. Attach platform frame (10.3) to the hooks of the main beam.
4. Attach guardrail (10.4) and fix by means of the captive bolts on the main beam.
5. Platform (10) is now completely assembled.

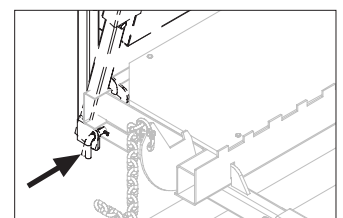
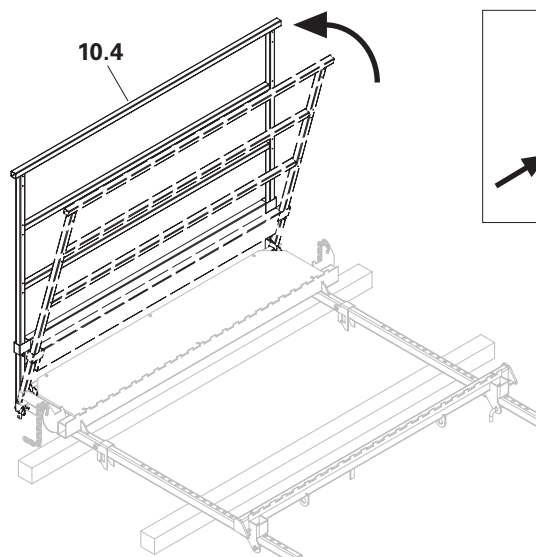
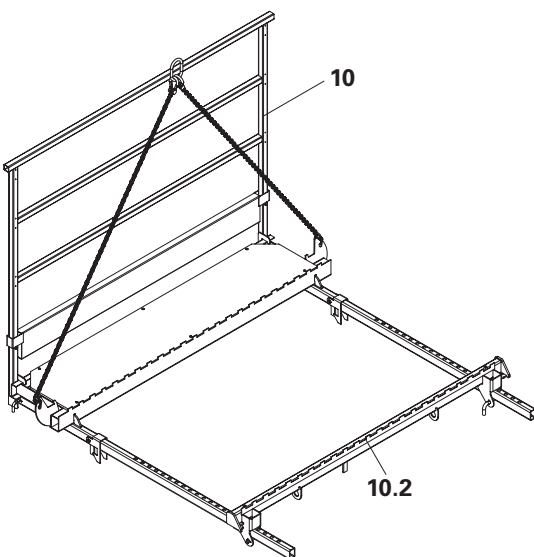
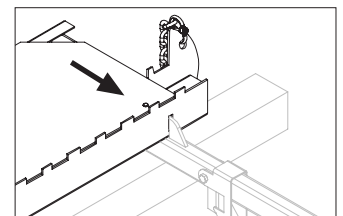
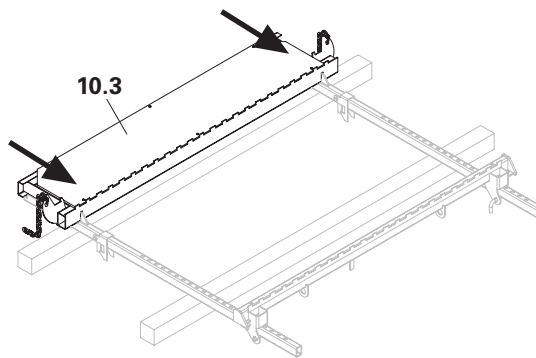
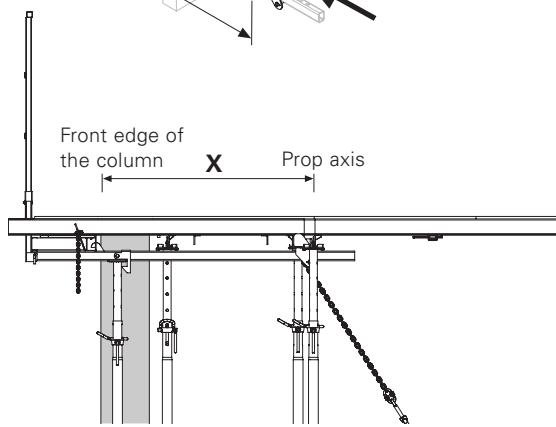
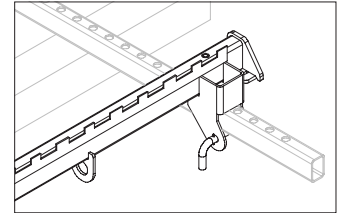
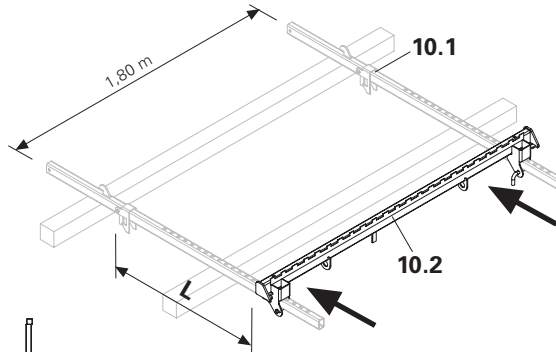

A8 Working and concreting scaffold

Installation of the platform

1. Push Main Beam (10.1) under the available element.
Mount Cross Beam (10.2) on propheads.
2. Lower platform (10) and lock in position on the two props at the edge of the building.
3. Tension platform with two chains (12.1) to the eyes of the cross beam (10.2)

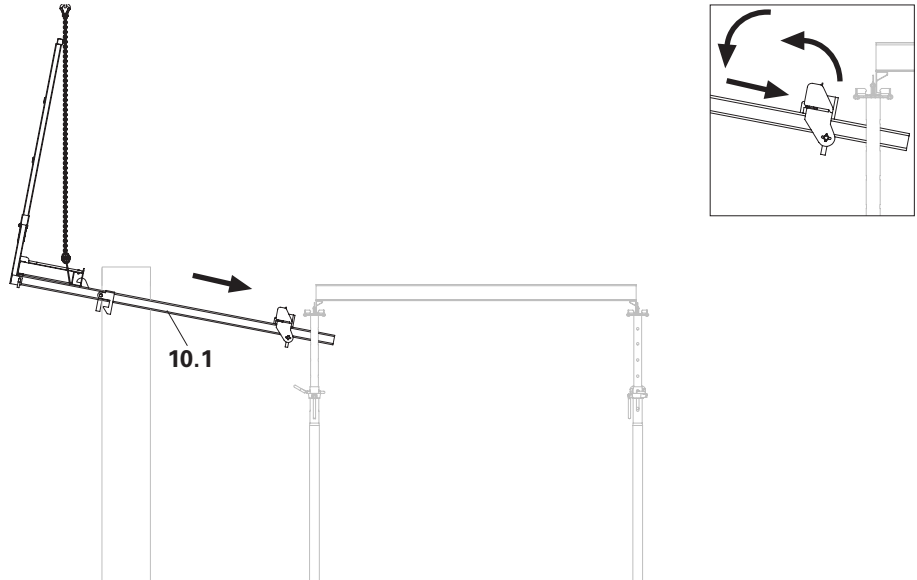

4. Lower lifting gear and then remove from a position on the assembly area (see Detail).



**The cantilevers may not be accessed before the bracing has been form-locked mounted!
The lifting gear must always be detached from a safe position on the assembly area!**

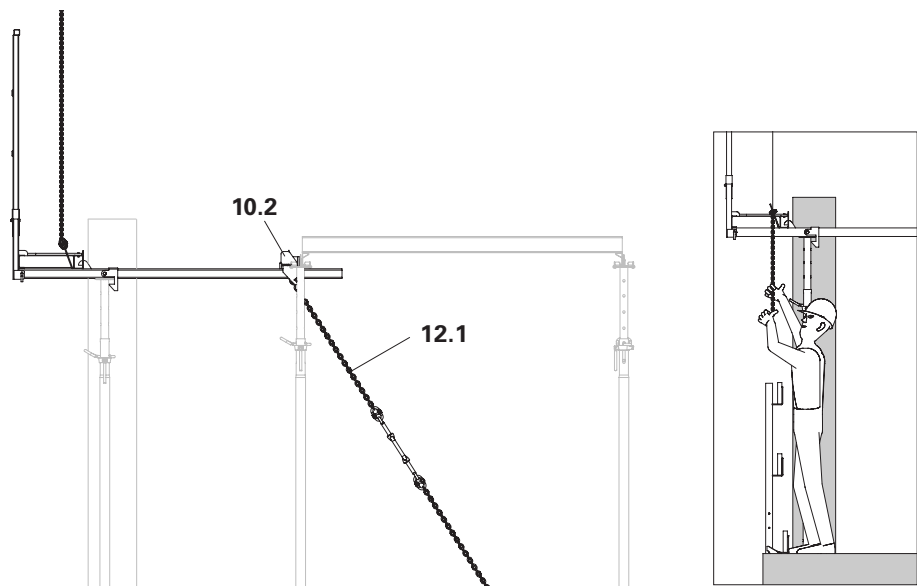

5. Support platform on the cross beam with a third prop without prophead (1.1) (supporting the slab prop on the cross beam).
6. Insert Filler Element GFL 183 x 20 (3b) from a safe position on the assembly area.
7. Support Filler Elements GFL 183 x 20 at interruptions with props (1) and connect by means of Clamps GFK (6), see top view.

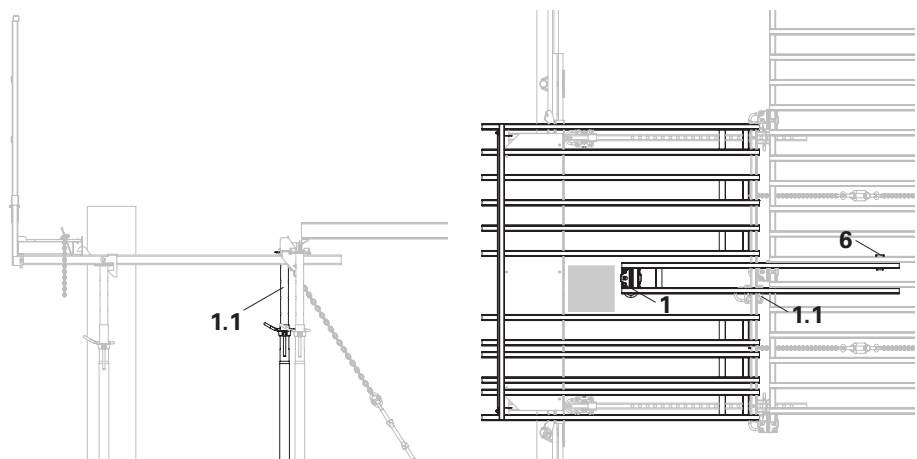

A9 Striking



Remove plywood sheets one after the other. Progressively secure edge props with tripods!
In infill areas, support Filler Element GFL 183 x 20 and GFL 150 x 100 with temporary props.

Striking guidelines for closed areas

Sequence must always be maintained!

- ① Filler Element GFC (3c), red
- ② Standard Element GFP (2), white
- ③ Filler Element GFL (3a, 3b), yellow

① Filler Element GFC

1. Remove Clamp GFK and Traverse GF 100.
2. Support Filler Element GFC with Shuttering Aid GFA
3. Lower prop for Filler Element GFC and then remove.
4. Turn Filler Element GFC and remove.

Striking guidelines for areas with open slab edges

without illustration

Sequence must always be maintained!

1. Turn cantilever (element with guardrail).
2. Remove bracing.
2. Further work steps: see above.

② Standard Element GFP

1. Lower props of the Standard Element GFP by approx. 3 cm.
2. Fold down Standard Element GFP with the Shuttering Aid GFA row by row and remove.
3. Remove props.
4. Continuously remove plywood form-lining.

③ Filler Element GFL

1. Remove Clamp GFK and Traverse GF 100.
2. Support Filler Element GFC with the Shuttering Aid GFA. Lower props and remove.
3. Turn Filler Element GFC and remove.
4. Remove Filler Element GFL 183 x 20 and props.
5. Remove Standard Element GFP and props.
6. Remove Filler Element GFL 150 x 100 and temporary props.

Clamps GFK and Traverse GF 100 have already been removed in the drawings!

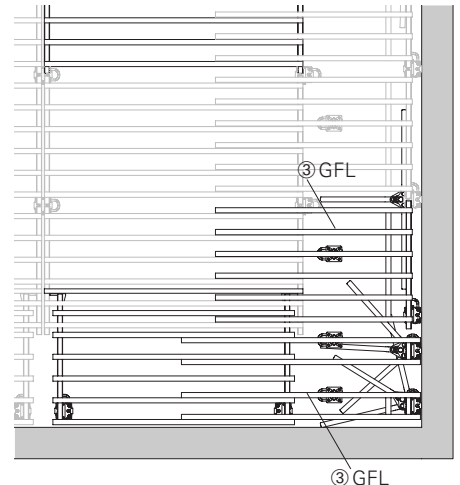
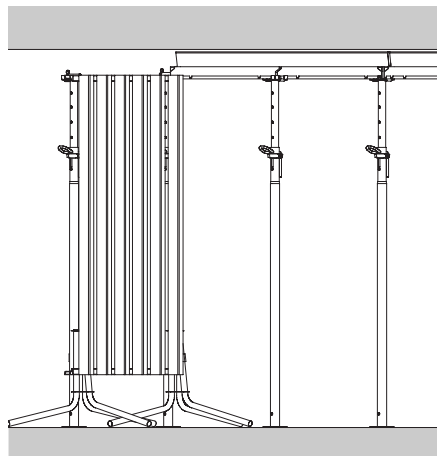
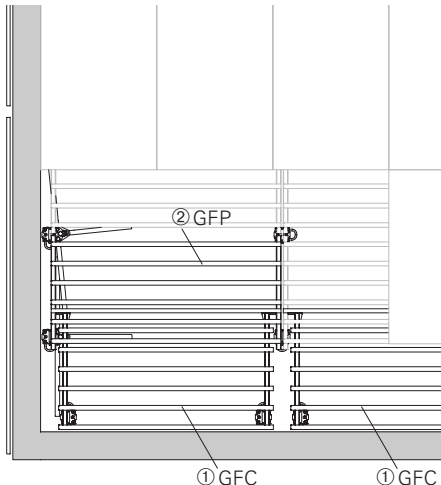

A10 Maintenance and cleaning

Careful handling of the formwork is required in order to maintain the value and operational readiness of the equipment over a long period of time.

Maintenance tips

1. Concrete vibrator with rubber end cap reduces the risk of damage to the formlining.
2. Spacers used for the reinforcement with large contact surfaces prevent impressions forming on the formlining.
3. Use support timbers if placing heavy objects in order to prevent impressions and damage to the formlining.
4. Spray components with PERI Bio Clean before every use and clean the rear side of the formwork with water immediately after concreting.
5. Spray moving parts, if required, with PERI Bio Clean.
6. PERI pallets and stacking pallets are available to provide suitable protection during transportation.

Due to the powder coating, cleaning requirements are kept to a minimum.

Prop Load, Evenness

Slab Thickness d [m]	Load Q* [kN/m ²]	Prop Load [kN]		Deflection Line**	
		without centre support	with centre support	without centre support	with centre support
0.10	4.2	8.6		7	
0.12	4.7	9.6		7	
0.14	5.2	10.6		7	
0.16	5.7	11.6		7	
0.18	6.2	12.6		7	
0.20	6.7	13.6	7.9	7	7
0.22	7.1	14.6	8.5	7	7
0.24	7.6	15.7	9.1	6	7
0.26	8.1	16.7	9.7	6	7
0.28	8.6	17.7	10.3	6	7
0.30	9.1	18.7	10.8	6	7
0.33	9.9	20.3	11.8	5	7
0.35	10.5		12.4		7
0.40	11.8		14.1		7
0.45	13.2		15.7		7
0.50	14.5		17.3		7
0.55	15.9		18.9		7
0.60	17.2		20.5		7
0.65	18.6		22.1		6
0.67	19.1		22.7		6

without centre support

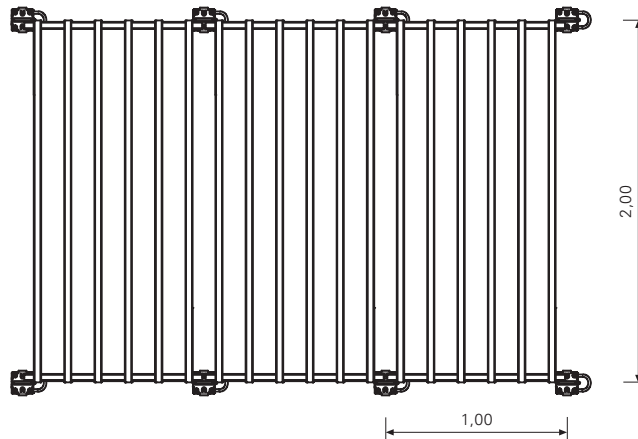

with centre support

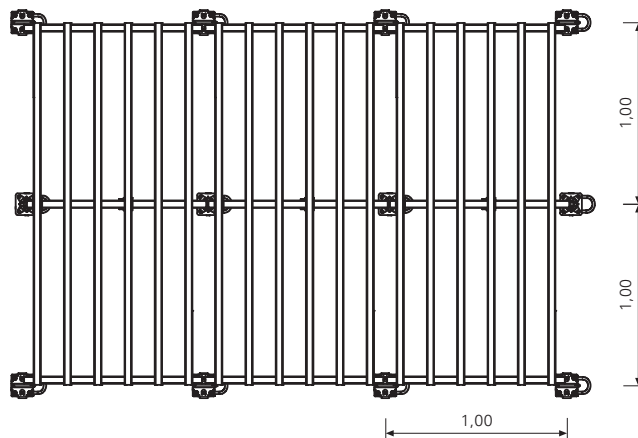

***load according to DIN EN 12812:**

Dead load $Q_1 = 0,25 \text{ kN/m}^2$

Concrete load $Q_{2,b} = 24,5 \text{ kN/m}^3 \times d \text{ [m]}$

Live load Working operations $Q_{2,p} = 0,75 \text{ kN/m}^2$

Live load Concreting $Q_4 = 0,1 \times Q_{2,b}$ (mit $0,75 \text{ kN/m}^2 < Q_4 < 1,75 \text{ kN/m}^2$)

Total Load Q = $Q_1 + Q_{2,b} + Q_{2,p} + Q_4$

For the specified prop loads, additional loads from the compensation areas must be taken into consideration.

The evenness is calculated with Fin-Ply 15 mm formlining.

Depending on the position of the formlining joints and size of the compensations, offsets can occur in the lateral infill areas without any additional measures.

** Evenness according to DIN 18202 assumes perfect levelling.

GRIDFLEX aluminium grid slab formwork

PEP 10

Permissible prop load [kN] in accordance with DIN EN 1065, Class A

Extension length [m]	PEP 10 – 250 A L = 1.47 – 2.50 m [kN]	PEP 10 – 300 A L = 1.72 – 3.00 m [kN]	PEP 10 – 350 A L = 1.97 – 3.50 m [kN]	PEP 10 – 400 A L = 2.22 – 4.00 m [kN]
1.50	25.0			
1.60	25.0			
1.70	25.0			
1.80	23.1	25.0		
1.90	20.8	24.9		
2.00	18.8	22.5	25.0	
2.10	17.0	20.4	23.8	
2.20	15.5	18.6	21.7	
2.30	14.2	17.0	19.8	22.7
2.40	13.0	15.6	18.2	20.8
2.50	12.0	14.4	16.8	19.2
2.60		13.3	15.5	17.8
2.70		12.3	14.4	16.5
2.80		11.5	13.4	15.3
2.90		10.7	12.5	14.3
3.00		10.0	11.7	13.3
3.10			10.9	12.5
3.20			10.3	11.7
3.30			9.6	11.0
3.40			9.1	10.4
3.50			8.6	9.8
3.60				9.3
3.70				8.8
3.80				8.3
3.90				7.9
4.00				7.5

Note:

The permissible values apply if using outer and inner tubes at the bottom.

PEP 20

Permissible Prop Load [kN] according to the Type Test

Extension Length [m]	PEP 20 N 260* L = 1.51 – 2.60 m		PEP 20 – 300 PEP 20 N 300* L = 1.71 – 3.00 m		PEP 20 – 350 PEP 20 N 350* L = 1.96 – 3.50 m		PEP 20 – 400 PEP 20 G 410* L = 2.21 – 4.00 m		PEP 20 – 500 L = 2.71 – 5.00	
	Outer Tube Bottom	Inner Tube Bottom	Outer Tube Bottom	Inner Tube Bottom	Outer Tube Bottom	Inner Tube Bottom	Outer Tube Bottom	Inner Tube Bottom	Outer Tube Bottom	Inner Tube Bottom
1.60	35.0	35.0								
1.70	35.0	35.0								
1.80	35.0	35.0	35.0	35.0						
1.90	35.0	35.0	35.0	35.0						
2.00	33.5	35.0	35.0	35.0	35.0	35.0				
2.10	31.9	35.0	32.2	35.0	35.0	35.0				
2.20	30.9	35.0	30.5	35.0	35.0	35.0				
2.30	29.8	35.0	29.0	35.0	35.0	35.0	35.0	35.0		
2.40	28.6	35.0	27.8	35.0	35.0	35.0	35.0	35.0		
2.50	27.1	32.9	26.9	35.0	35.0	35.0	35.0	35.0		
2.60	24.8	29.4	26.1	35.0	33.8	35.0	35.0	35.0		
2.70			24.9	31.7	32.4	35.0	35.0	35.0		
2.80			23.3	28.5	31.2	35.0	35.0	35.0	35.0	35.0
2.90			21.6	25.7	30.2	35.0	35.0	35.0	35.0	35.0
3.00			20.0	23.2	29.2	35.0	35.0	35.0	35.0	35.0
3.10					27.5	34.6	33.6	35.0	35.0	35.0
3.20					25.7	31.5	32.5	35.0	35.0	35.0
3.30					24.1	28.8	31.2	35.0	35.0	35.0
3.40					22.4	26.4	29.6	35.0	35.0	35.0
3.50					20.7	24.1	27.8	33.9	35.0	35.0
3.60							26.1	31.2	35.0	35.0
3.70							24.5	28.9	35.0	35.0
3.80							23.0	26.8	35.0	35.0
3.90							21.6	24.8	35.0	35.0
4.00							20.1	22.8	34.2	35.0
4.10									32.3	35.0
4.20									30.6	35.0
4.30									28.9	34.0
4.40									27.4	31.9
4.50									26.0	29.9
4.60									24.6	28.1
4.70									23.4	26.4
4.80									22.1	24.9
4.90									20.9	23.4
5.00									20.0	21.8

All PEP 20 Props conform with DIN EN 1065 class D with a permissible load for the entire extension range of minimum 20 kN.

All PEP 20 Props clamped in the Table Swivel Head or UNIportal Head fitted to PERI tableforms have a permissible load of minimum 30 kN over the entire extension range.

*For the N and G Props the application Inner Tube at Bottom is only possible with PERI Slab Tables or SKYDECK (bolted head).

GRIDFLEX aluminium grid slab formwork

PEP 30

Permissible Prop Load [kN] according to the Type Test

Extension Length [m]	PEP 30 – 150 L = 0.96 – 1.50 m		PEP 30 – 250 L = 1.46 – 2.50 m		PEP 30 – 300 PEP 30 G 300* L = 1.71 – 3.00 m		PEP 30 – 350 PEP 30 G 350* L = 1.96 – 3.50 m		PEP 30 – 400 L = 2.21 – 4.00 m	
	Outer Tube Bottom	Inner Tube Bottom	Outer Tube Bottom	Inner Tube Bottom	Outer Tube Bottom	Inner Tube Bottom	Outer Tube Bottom	Inner Tube Bottom	Outer Tube Bottom	Inner Tube Bottom
1.00	35.0	35.0								
1.10	35.0	35.0								
1.20	35.0	35.0								
1.30	34.9	35.0								
1.40	34.2	35.0								
1.50	33.5	35.0	40.0	40.0						
1.60			40.0	40.0						
1.70			40.0	40.0						
1.80			40.0	40.0	40.0	40.0				
1.90			38.5	40.0	40.0	40.0				
2.00			36.8	40.0	40.0	40.0	40.0	40.0		
2.10			35.3	40.0	40.0	40.0	40.0	40.0		
2.20			34.4	40.0	40.0	40.0	40.0	40.0		
2.30			33.3	40.0	40.0	40.0	40.0	40.0	40.0	40.0
2.40			32.1	37.6	40.0	40.0	40.0	40.0	40.0	40.0
2.50			30.1	34.8	39.9	40.0	40.0	40.0	40.0	40.0
2.60					38.8	40.0	40.0	40.0	40.0	40.0
2.70					37.4	40.0	40.0	40.0	40.0	40.0
2.80					35.8	40.0	40.0	40.0	40.0	40.0
2.90					33.2	37.2	40.0	40.0	40.0	40.0
3.00					30.4	33.8	40.0	40.0	40.0	40.0
3.10							40.0	40.0	40.0	40.0
3.20							37.6	40.0	40.0	40.0
3.30							35.0	37.6	40.0	40.0
3.40							32.3	34.6	40.0	40.0
3.50							30.0	31.6	40.0	40.0
3.60									40.0	40.0
3.70									40.0	40.0
3.80									37.4	40.0
3.90									34.8	37.0
4.00									32.2	33.9

All PEP 30 Props conform with DIN EN 1065 class E with a permissible load for the entire extension range of minimum 30 kN.

All PEP 30 Props clamped in the Table Swivel Head or UNIportal Head fitted to PERI tableforms have a permissible load of minimum 40 kN (PEP 30-150 = 35 kN) over the entire extension range.

*For the N and G Props the application Inner Tube at Bottom is only possible with PERI Slab Tables or SKYDECK (bolted head).

Item no.	Weight kg
110038	20,300

Standard Element GFP 200 x 100
Aluminium, nailable, white powder-coated.

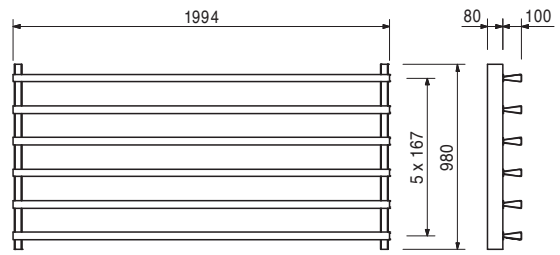
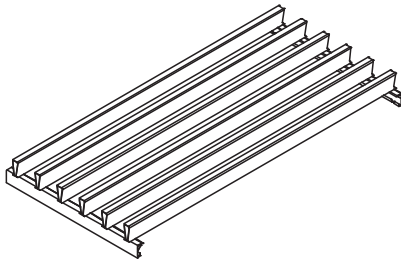

110040	22,100
--------	--------

Filler Element Cross GFC 200 x 100
Aluminium, nailable, red powder-coated.

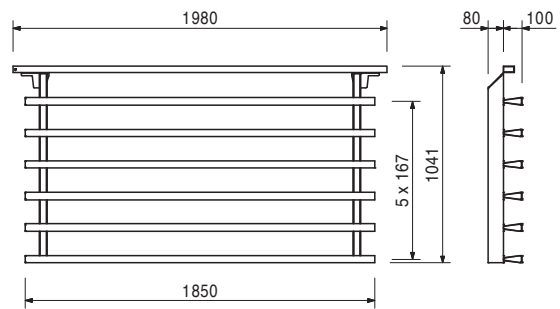
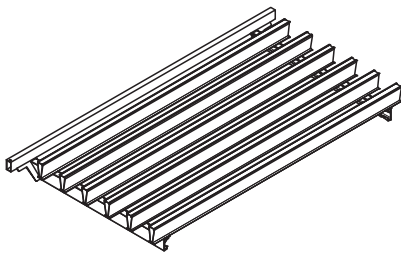

110486	15,000
--------	--------

Filler Element Longitudinal GFL 150 x 100
Aluminium, nailable, yellow powder-coated.

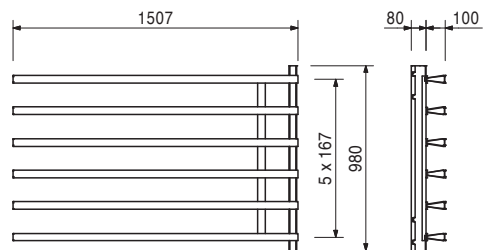
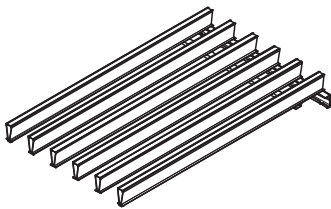

110646	5,800
--------	-------

Filler Element Longitudinal GFL 183 x 20
Aluminium, nailable, yellow powder-coated.

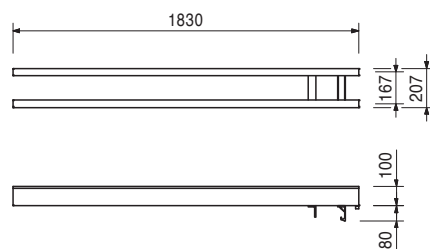
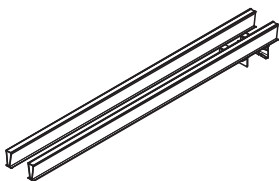

Item no.	Weight kg
109910	0,845

Prophead GFH, galv.
With spring retention. Supports GRIDFLEX elements.

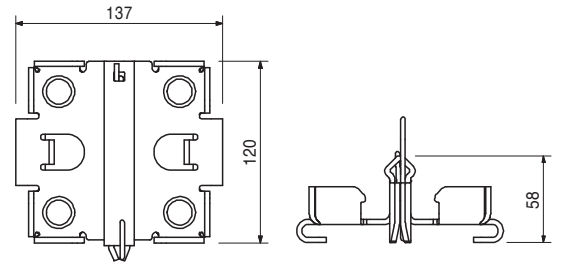
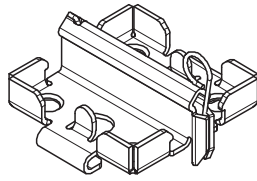

110238	4,880
--------	-------

Wall Holder GFW
For horizontal anchoring of the formwork to the wall.

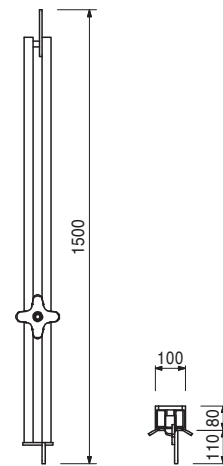
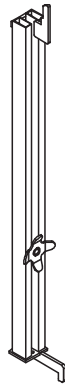

110044	2,370
--------	-------

Shuttering Aid GFA
Used when shuttering with GRIDFLEX.

Technical Data
Adjustable in 7.5 cm increments.

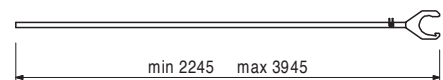
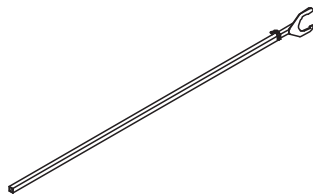

110326	7,150
--------	-------

Guardrail GF 100
As guardrail for cantilevers. Guardrail height above top edge of plywood = 1.30 m.

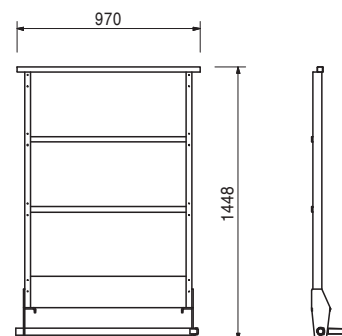
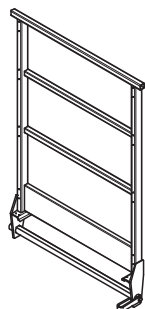

Item no.	Weight kg
110556	0,797

Clamp GFK, galv.
For attaching filler elements to standard elements.

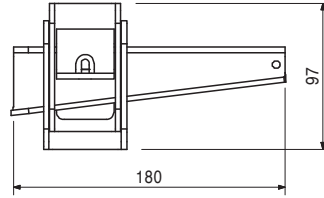
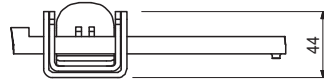
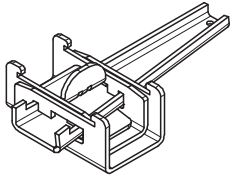

110045	5,120
--------	-------

Traverse GF 100
With locking wedge for mounting to the main beam of the elements.

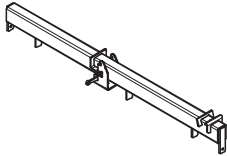

Note
For assembling longitudinal filler elements, with props as centre support and cantilever element support at the slab edge.

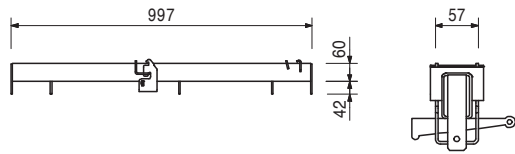

110595	0,411
--------	-------

Tension Sleeve GFO
For bracing e.g. cantilevered elements.

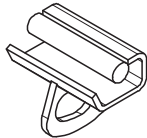

Technical Data
Permissible tension force 3.0 kN.

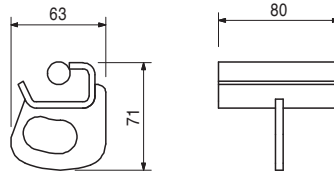

065074	0,450
--------	-------

Turnbuckle 3.0 kN, M 12

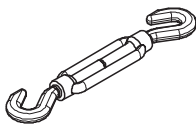

Technical Data
Permissible tension force 3.0 kN.

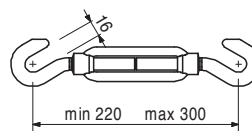

065073	1,370
--------	-------

Anchor Chain 3.0 kN, l = 2.5 m

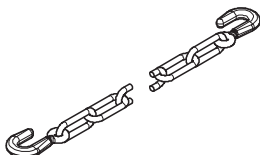

Technical Data
Permissible tension force 3.0 kN.

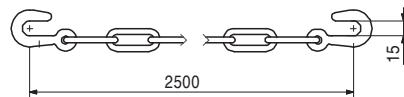

Item no.	Weight kg		
028100	1,830	Base Plate RS	Complete with

For mounting RS push-pull props.

1 pc. 018050 Pin \varnothing 16 x 65/86, galv.
1 pc. 018060 Cotter Pin 4/1, galv.

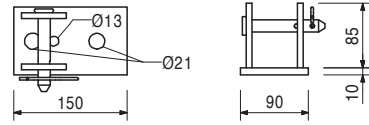
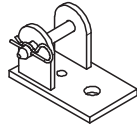

111291	4,600	Head Spindle GTR 38-70/50	
--------	-------	----------------------------------	--

For using GRIDFLEX in combination with PERI UP shoring.

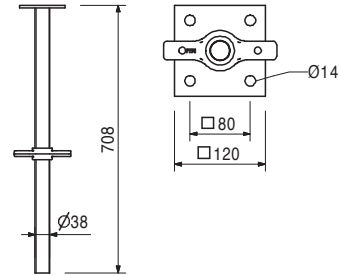
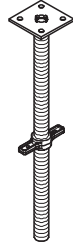

110939	21,700	Stacking Pallet GRIDFLEX, galv.	Complete with
--------	--------	--	----------------------

For stacking 10 Standard Elements GFP 200 x 100, Filler Elements Lateral GFC 200 x 100 or Filler Elements Longitudinal GFL 150 x 100 respectively. Suitable for crane and fork-lift transportation. 2 pieces per stack.

2 x 111392 Pallet Extension GF 10
Safety instructions
Follow Instructions for Use! Load capacity 175 kg.

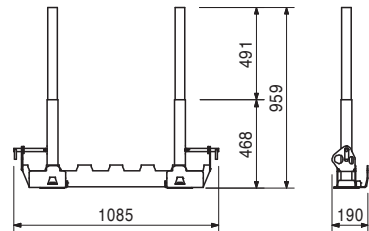
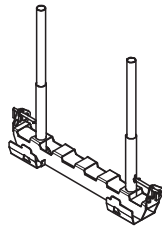

111392	2,970	Pallet Extension GF 10	
--------	-------	-------------------------------	--



115427	2,090	Tension Strap Rail GF 92	
--------	-------	---------------------------------	--

As transport protection for GRIDFLEX Elements GFP 200 x 100 and GFL 150 x 100. Yellow powder-coated.

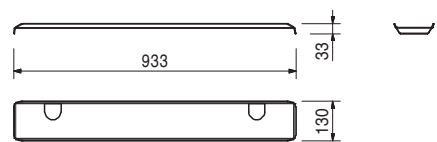
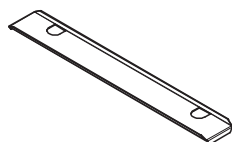

Item no.	Weight kg
115385	4,230

Tension Strap Rail GF 125

As transport protection for GRIDFLEX Elements GFC 200 x 100. Red powder-coated.

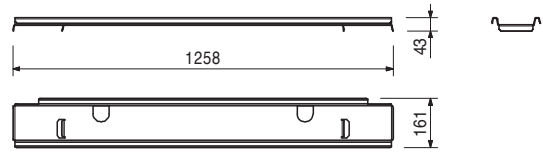
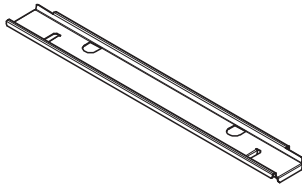

111396	16,200
--------	--------

Pallet RP 80 x 110, galv.

For stacking Guardrail GF 100.

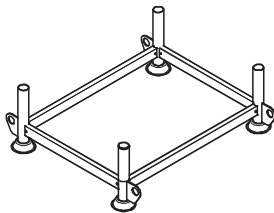

Safety instructions

Follow Instructions for Use! Load capacity 500 kg.

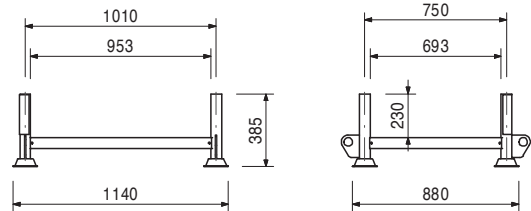

111392	2,970
--------	-------

Accessories

Pallet Extension GF 10

111738	64,000
--------	--------

Pallet GF 85 x 210, galv.

For stacking and transporting GRIDFLEX Filler Element GFL 183 x 20 and Main Beam BD 210 or Cross Beam BD 210.

Safety instructions

Follow Instructions for Use!
Load capacity 1.5 t.

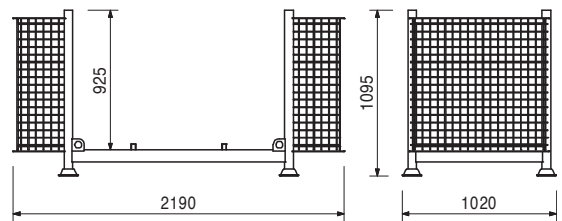
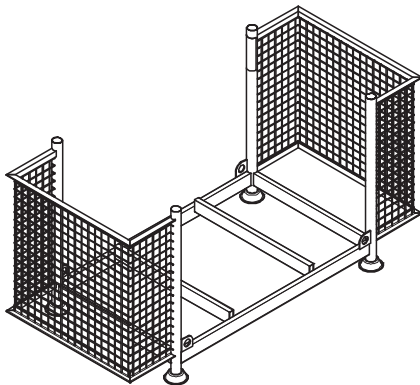

Item no.	Weight kg
111566	106,000

Platform GIP 200, complete

Platform with 12 mm thick platform lining and insertable guardrail. Delivered as individual components.

Complete with

- 1 x 111703 Platform Frame GIP 200
- 1 x 111700 Platform Guardrail GIP 200
- 2 x 111702 Main Beam GIP 200
- 1 x 111701 Secondary Beam GIP 200

Technical Data

Permissible live load 150 kg/m².

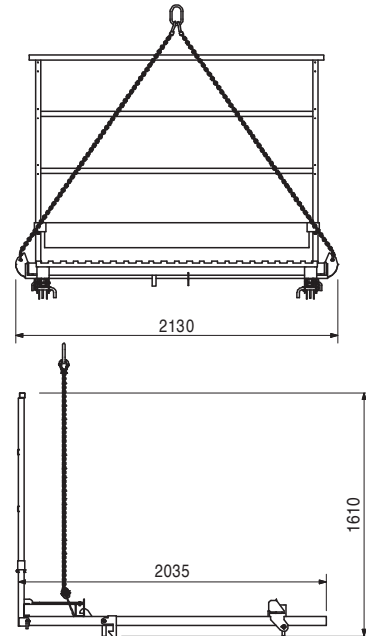
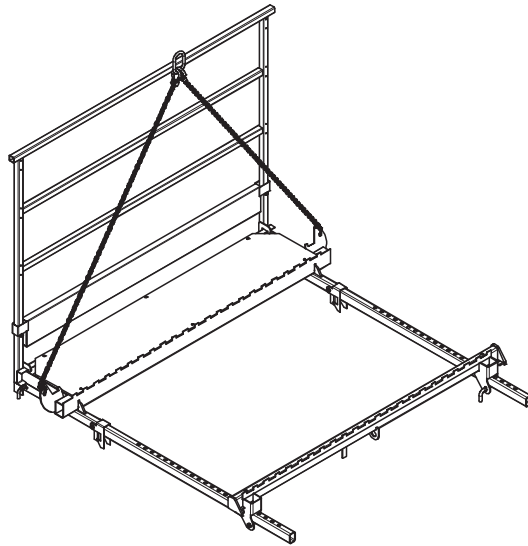

111379	265,000
--------	---------

Corner Platform GCP, complete

Platform with 21 mm thick platform lining and insertable guardrail. Delivered as individual components.

Complete with

- 1 x 111378 Corner Platform GCP
- 2 x 111332 Guardrail GCP 130, galv.
- 1 x 111340 Guardrail GCP 160, galv.
- 1 x 111324 Internal Angle GCP

Technical Data

Permissible live load 150 kg/m².

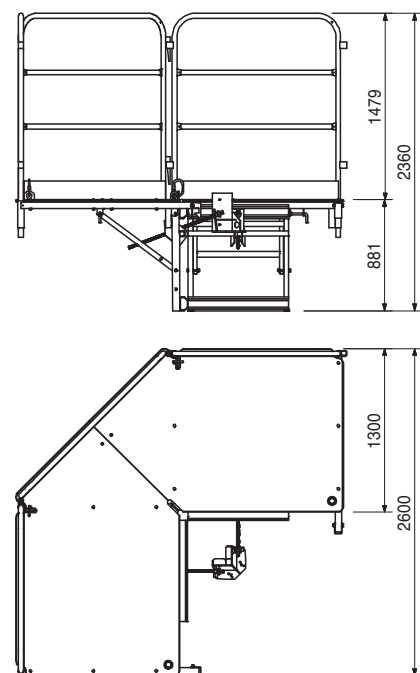
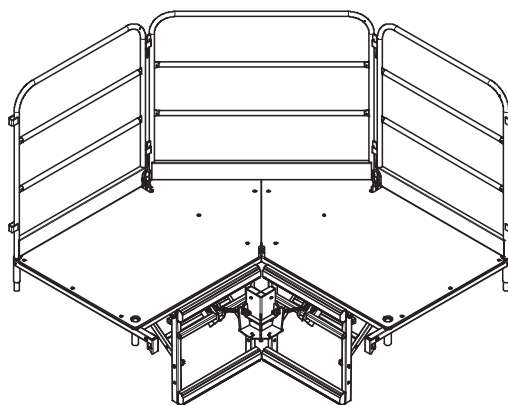

PERI International

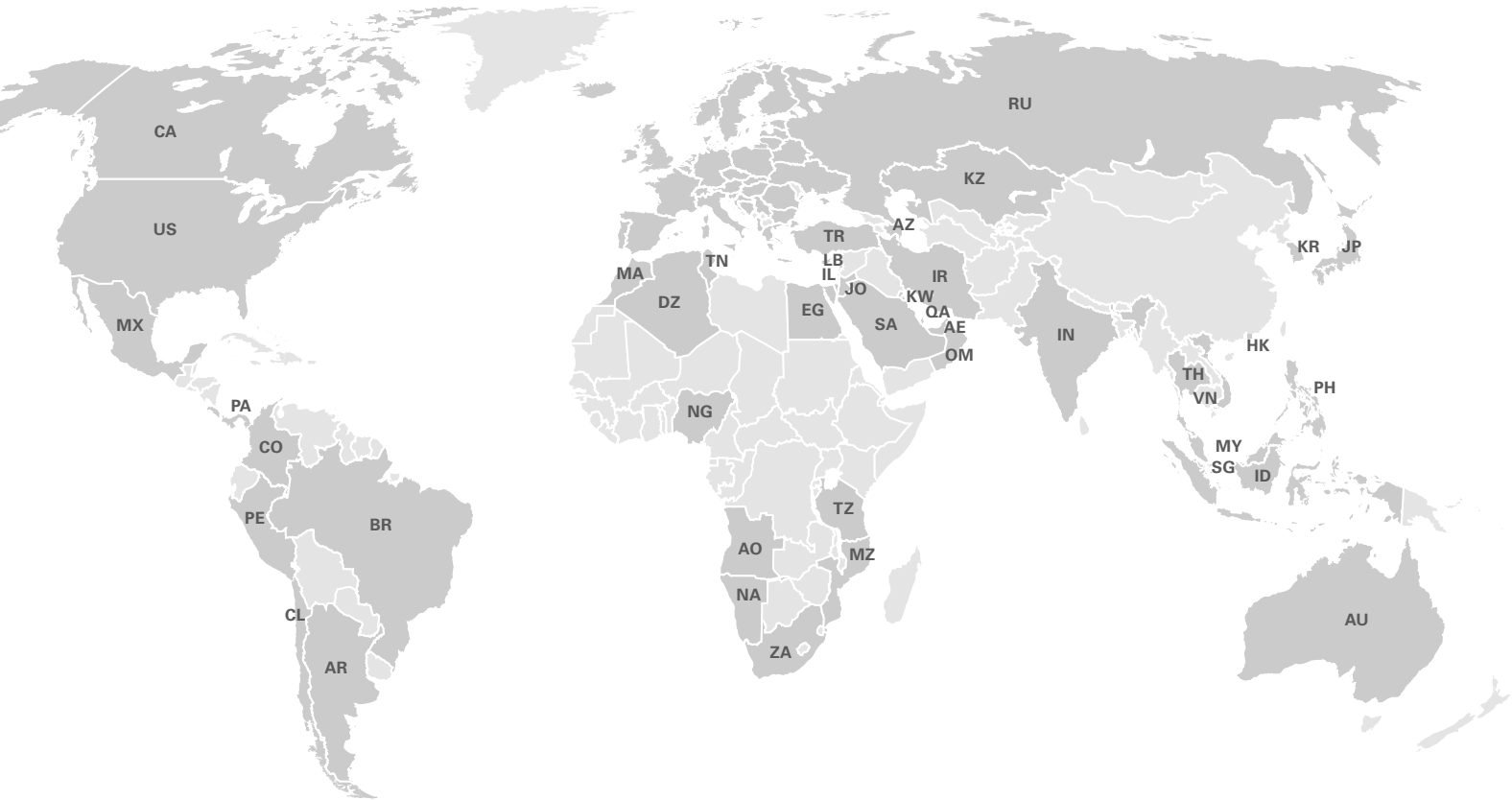

North America

- CA** Canada
PERI Formwork Systems, Inc.
www.peri.ca
- MX** Mexico
PERI Cimbras y Andamios, S.A. de C.V.
www.peri.com.mx
- PA** Panama
PERI Panama Inc.
www.peri.com.pa
- US** USA
PERI Formwork Systems, Inc.
www.peri-usa.com

South America

- AR** Argentina
PERI S.A.
www.peri.com.ar
- BR** Brazil
PERI Formas e Escoramentos Ltda.
www.peribrasil.com.br
- CL** Chile
PERI Chile Ltda.
www.peri.cl
- CO** Colombia
PERI S.A.S.
www.peri.com.co
- PE** Peru
PERI Peruana S.A.C.
www.peri.com.pe

Africa

- AO** Angola
Pericofragens, Lda.
www.peri.pt
- DZ** Algeria
S.A.R.L. PERI
www.peri.dz
- EG** Egypt
Egypt Branch Office
www.peri.com.eg
- MA** Morocco
PERI S.A.
www.peri.ma
- MZ** Mozambique
PERI (Pty.) Ltd.
www.peri.co.mz
- NA** Namibia
PERI (Pty.) Ltd.
www.peri.na
- NG** Nigeria
PERI Nigeria Ltd.
www.peri.ng
- TN** Tunisia
PERI S.A.U.
www.peri.es
- TZ** Tanzania
PERI Formwork and Scaffolding Ltd
www.peri.co.tz
- ZA** South Africa
PERI Formwork Scaffolding (Pty) Ltd
www.peri.co.za

Asia

- AE** United Arab Emirates
PERI (L.L.C.)
www.peri.ae
- AZ** Azerbaijan
PERI Representative Office
www.peri.com.tr
- HK** Hong Kong
PERI (Hong Kong) Limited
www.perihk.com
- ID** Indonesia
PT Beton Perkasa Wijaksana
www.betonperkasa.com
- IL** Israel
PERI F.E. Ltd.
www.peri.co.il
- IN** India
PERI (India) Pvt Ltd
www.peri.in
- IR** Iran
PERI Pars. Ltd.
www.peri.ir
- JO** Jordan
PERI GmbH – Jordan
www.peri.com
- JP** Japan
PERI Japan K.K.
www.peri.co.jp
- KR** Korea
PERI (Korea) Ltd.
www.perikorea.com
- KW** Kuwait
PERI Kuwait W.L.L.
www.peri.com.kw
- KZ** Kazakhstan
TOO PERI Kazakhstan
www.peri.kz
- LB** Lebanon
PERI Lebanon Sarl
lebanon@peri.de
- MY** Malaysia
PERI Formwork Malaysia Sdn. Bhd.
www.perimalaysia.com
- OM** Oman
PERI (L.L.C.)
www.peri.ae
- PH** Philippines
PERI-Asia Philippines, INC.
www.peri.com.ph
- QA** Qatar
PERI Qatar LLC
www.peri.qa
- SA** Saudi Arabia
PERI Saudi Arabia Ltd.
www.peri.com.sa
- SG** Singapore
PERI Asia Pte Ltd
www.periasia.com
- TH** Thailand
Peri (Thailand) Co., Ltd.
www.peri.co.th
- TR** Turkey
PERI Kalıp ve İskeleleri
www.peri.com.tr
- VN** Vietnam
PERI ASIA PTE LTD
www.peri.com.vn



**PERI GmbH
Formwork Scaffolding Engineering**

Rudolf-Diesel-Strasse 19
89264 Weissenhorn
Germany
Tel. +49 (0)7309.950-0
Fax +49 (0)7309.951-0
info@peri.com
www.peri.com

Oceania

AU Australia
PERI Australia Pty. Ltd.
www.periaus.com.au

DK Denmark
PERI Danmark A/S
www.peri.dk

IT Italy
PERI S.r.l.
www.peri.it

SE Sweden
PERI Sverige AB
www.peri.se

Europe

EE Estonia
PERI AS
www.peri.ee

LT Lithuania
PERI UAB
www.peri.lt

SI Slovenia
PERI oplate i skele d.o.o
www.peri.com.hr

AL Albania
PERI Kalıp ve İskeleleri
www.peri.com.tr

ES Spain
PERI S.A.U.
www.peri.es

LU Luxembourg
N.V. PERI S.A.
www.peri.lu

SK Slovakia
PERI spol. s. r.o.
www.peri.sk

AT Austria
PERI Ges.mbH
www.peri.at

FI Finland
PERI Suomi Ltd. Oy
www.perisuomi.fi

LV Latvia
PERI SIA
www.peri-latvija.lv

UA Ukraine
TOW PERI
www.peri.ua

BA Bosnia and Herzegovina
PERI oplate i skele d.o.o
www.peri.com.hr

FR France
PERI S.A.S.
www.peri.fr

NL Netherlands
PERI b.v.
www.peri.nl

BE Belgium
PERI N.V.
www.peri.be

GB United Kingdom
PERI Ltd.
www.peri.ltd.uk

NO Norway
PERI Norge AS
www.peri.no

BG Bulgaria
PERI Bulgaria EOOD
www.peri.bg

GR Greece
PERI Hellas Ltd.
www.perihellas.gr

PL Poland
PERI Polska Sp. z o.o.
www.peri.com.pl

BY Belorussia
IOOO PERI
www.peri.by

HR Croatia
PERI oplate i skele d.o.o.
www.peri.com.hr

PT Portugal
Pericofragens Lda.
www.peri.pt

CH Switzerland
PERI AG
www.peri.ch

HU Hungary
PERI Kft.
www.peri.hu

RO Romania
PERI România SRL
www.peri.ro

CZ Czech Republic
PERI spol. s r.o.
www.peri.cz

IR Ireland
Siteserv Access & Formwork
www.siteservaccess.ie

RS Serbia
PERI oplate d.o.o.
www.peri.rs

DE Germany
PERI GmbH
www.peri.de

IS Iceland
Armar ehf.
www.armor.is

RU Russia
OOO PERI
www.peri.ru

**The optimal System
for every Project and
every Requirement**



Wall Formwork



Column Formwork



Slab Formwork



Climbing Systems



Bridge Formwork



Tunnel Formwork



Shoring Systems



Construction Scaffold



Facade Scaffold



Industrial Scaffold



Access



Protection Scaffold



Safety Systems



System-Independent Accessories



Services



PERI GmbH
Formwork Scaffolding Engineering
 Rudolf-Diesel-Strasse 19
 89264 Weissenhorn
 Germany
 Tel. +49 (0)7309.950-0
 Fax +49 (0)7309.951-0
 info@peri.com
 www.peri.com